

GENERAL NOTES:

- PRIOR TO SUBMITTING BID, VISIT THE JOB SITE AND BECOME FULLY ACQUAINTED WITH THE EXISTING CONDITIONS OF THE PROJECT. REVIEW THE GENERAL NOTES, SPECIFICATIONS AND OTHER DRAWINGS FOR ADDITIONAL REQUIREMENTS WHICH MAY NOT BE SPECIFICALLY CALLED OUT IN THIS PORTION OF THE CONSTRUCTION DOCUMENTS. NOTIFY ARCHITECT, ENGINEER AND/OR OWNER OF CONFLICTS OR DISCREPANCIES PRIOR TO SUBMISSION OF BID.
- PROVIDE SEISMIC RESTRAINTS AS NEEDED FOR THE MECHANICAL SYSTEMS IN THE PROJECT BASED ON THE SEISMIC ANALYSIS REQUIRED BY THE SPECIFICATIONS.
- COORDINATE THE INSTALLATION OF THE MECHANICAL SYSTEMS WITH OTHER TRADES TO ENSURE A NEAT AND ORDERLY INSTALLATION. INSTALL DUCTWORK AND PIPING AS TIGHT TO STRUCTURE AS POSSIBLE. COORDINATE WITH ELECTRICAL, PLUMBING, AND MECHANICAL TRADES TO AVOID CONFLICTS WITH ELECTRICAL PANELS, LIGHTING FIXTURES, ETC. ANY MODIFICATIONS REQUIRED DUE TO LACK OF COORDINATION WILL BE THE RESPONSIBILITY OF THE CONTRACTOR AT NO EXTRA COST TO THE OWNER.
- ALL MECHANICAL EQUIPMENT SHOWN ON THE MECHANICAL PLANS SHALL BE PROVIDED BY DIVISION 23 UNLESS OTHERWISE NOTED.
- NEW MECHANICAL EQUIPMENT, DUCTWORK AND PIPING ARE SHOWN AT APPROXIMATE LOCATIONS. FIELD MEASURE FINAL DUCTWORK AND PIPING LOCATIONS PRIOR TO FABRICATION AND MAKE ADJUSTMENTS AS REQUIRED TO FIT THE DUCTWORK AND PIPING WITHIN THE AVAILABLE SPACE. VERIFY THAT FINAL EQUIPMENT LOCATIONS MEET MANUFACTURER'S RECOMMENDATIONS REGARDING SERVICE CLEARANCE AND PROPER AIRFLOW CLEARANCE AROUND EQUIPMENT.
- REFER TO ARCHITECTURAL DRAWINGS FOR RELATED CONSTRUCTION DETAILS AS APPLICABLE TO THE HVAC SYSTEM. VERIFY CHASES AND PENETRATIONS SHOWN ON ARCHITECTURAL DRAWINGS THAT ARE INTENDED FOR DUCTWORK AND PIPING MEET REQUIREMENTS.
- COORDINATE LOCATION OF ROOF MOUNTED HVAC EQUIPMENT AND ROOF PENETRATIONS WITH THE ARCHITECTURAL AND STRUCTURAL DRAWINGS.
- INDOOR AIR QUALITY MEASURES: PROTECT INSIDE OF (INSTALLED AND DELIVERED) DUCTWORK AND HVAC UNITS FROM EXPOSURE TO DUST, DIRT, PAINT AND MOISTURE. REPLACE INSULATION THAT HAS BECOME WET AT ANY TIME DURING CONSTRUCTION. DRYING THE INSULATION IS NOT ACCEPTABLE. SEAL ANY TEARS OR JOINTS OF INTERNAL FIBERGLASS INSULATION. REMOVE DEBRIS FROM CEILING/RETURN AIR PLENUM INCLUDING DUST. AN INDEPENDENT, PROFESSIONAL DUCT CLEANING COMPANY SHALL VACUUM CLEAN ANY DUCTWORK CONNECTED TO HVAC UNITS THAT WERE OPERATED DURING THE CONSTRUCTION PERIOD AFTER NEW FILTERS ARE INSTALLED AND PRIOR TO TURNING SYSTEM OVER TO THE OWNER. THE INTERNAL SURFACES AND ASSOCIATED COILS OF ANY HVAC UNITS THAT WERE OPERATED SHALL ALSO BE CLEANED.
- INSTALL DUCTWORK AND PIPING PARALLEL TO BUILDING COLUMN LINES UNLESS OTHERWISE SHOWN OR NOTED.
- OVERHEAD HANGERS AND SUPPORTS FOR EQUIPMENT, DUCTWORK AND PIPING SHALL BE FASTENED TO BUILDING JOISTS OR BEAMS. DO NOT ATTACH HANGERS AND SUPPORTS TO THE ABOVE FLOOR SLAB OR ROOF EXCEPT WHERE CONCRETE INSERTS IN CONCRETE SLABS ARE ALLOWED BY THE SPECIFICATIONS.
- COORDINATE LOCATION OF EQUIPMENT SUPPORTS WITH LOCATION OF EQUIPMENT ACCESS PANELS/DOORS TO ENABLE SERVICE OF EQUIPMENT AND/OR FILTER REPLACEMENT.
- SEAL PENETRATIONS THROUGH THE BUILDING COMPONENTS IN ACCORDANCE WITH THE CONTRACT SPECIFICATIONS. FIREPROOF PENETRATIONS THROUGH FIRE RATED COMPONENTS IN ACCORDANCE WITH U.L. REQUIREMENTS.
- COORDINATE THE EXACT MOUNTING SIZE AND FRAME TYPE OF DIFFUSERS, REGISTERS AND GRILLES WITH THE SUPPLIER TO MEET THE CEILING, WALL AND DUCT INSTALLATION REQUIREMENTS.
- ADJUST LOCATION OF CEILING DIFFUSERS, REGISTERS AND GRILLES AS REQUIRED TO ACCOMMODATE FINAL CEILING GRID AND LIGHTING LOCATIONS.
- PAINT PORTIONS OF DUCTWORK AND INSULATION THAT ARE EXPOSED TO VIEW BY THE INSTALLATION OF DIFFUSERS, REGISTERS, AND GRILLES IN CEILINGS OR WALLS FLAT BLACK. PORTIONS INCLUDE BOTH THE INTERIOR OF UNLINED DUCTWORK AND THE EXTERIOR OF DUCTWORK AND INSULATION.
- DUCTWORK CROSSING FIRE RATED WALLS OR OTHER FIRE RATED ASSEMBLIES SHALL BE MINIMUM 26 GAUGE SHEET METAL.
- PROVIDE FIRE OR FIRE/SMOKE DAMPERS, AS APPLICABLE, IN DUCTWORK AT CEILINGS AND WALLS AT LOCATIONS SHOWN ON THE PLANS. FIRE AND FIRE/SMOKE DAMPERS SHALL CONFORM TO NFPA AS APPLICABLE. COORDINATE SLEEVE LENGTH WITH REQUIREMENTS OF INSTALLED LOCATION.
- PROVIDE DUCT ACCESS PANELS OR DOORS FOR ACCESS TO FIRE AND FIRE/SMOKE DAMPERS. ACCESS PANEL OR DOOR SHALL BE MINIMUM SIZE OF 10" BY 10" AND SHALL BE INSTALLED WITHIN 12" OF DAMPER. PROVIDE A REMOVABLE DUCT SECTION WHERE DUCT SIZE IS TOO SMALL FOR A 10" BY 10" ACCESS DOOR.
- LOCATE AND SET THERMOSTATS AND HUMIDISTATS AT LOCATIONS SHOWN ON PLANS. VERIFY EXACT LOCATIONS WITH ARCHITECT PRIOR TO INSTALLATION. DEVICE MOUNTING HEIGHT SHALL MEET ADA REQUIREMENTS UNLESS OTHERWISE NOTED ON PLANS. PROVIDE INSULATED BACKING FOR THERMOSTATS MOUNTED ON EXTERIOR BUILDING WALLS. INSTALL WIRING IN CONDUIT PROVIDED BY DIVISION 26. AT A MINIMUM, PROVIDE CONDUIT IN THE WALL FROM THE JUNCTION BOX TO 6" ABOVE THE CEILING.
- COORDINATE THE LOCATION AND ELEVATION OF WALL-MOUNTED DEVICES WITH PRESENTATION BOARDS, DISPLAY CABINETS, SHELVES OR OTHER COMPONENTS SHOWN ON THE ARCHITECTURAL DRAWINGS THAT ARE TO BE INSTALLED UNDER OTHER DIVISIONS. CONTRACTOR WILL NOT BE REIMBURSED FOR RELOCATION OF WALL-MOUNTED DEVICES CAUSED BY A LACK OF COORDINATION.
- PROVIDE A MANUAL BALANCING DAMPER IN EACH DUCT TAKEOFF FROM SUPPLY, RETURN, OUTDOOR AND EXHAUST AIR DUCTS.
- PROVIDE A PREFABRICATED 45 DEGREE, HIGH EFFICIENCY, RECTANGULAR/ROUND BRANCH DUCT TAKEOFF FITTING FOR BRANCH DUCT CONNECTIONS AND TAKE-OFFS TO INDIVIDUAL DIFFUSERS, REGISTERS AND GRILLES. PROVIDE WITH INTEGRAL MANUAL BALANCING DAMPER AND LOCKING QUADRANT WHERE INDICATED ON PLANS.
- BRANCH DUCTWORK TO AIR OUTLETS SHALL BE SAME SIZE AS OUTLET NECK SIZE UNLESS OTHERWISE NOTED.
- REFER TO SPECIFICATIONS FOR DUCTWORK AND PIPING INSULATION REQUIREMENTS. DUCT SIZES ON MECHANICAL PLANS INDICATE CLEAR INSIDE AIRFLOW DIMENSIONS. INCREASE SHEET METAL SIZES ACCORDINGLY TO ACCOUNT FOR THICKNESS OF DUCT LINER.
- FLEXIBLE DUCTWORK SHALL NOT EXCEED 5'-0" IN LENGTH AND SHALL BE INSTALLED AND SUPPORTED TO AVOID SHARP BENDS AND SAGGING. REFER TO SPECIFICATIONS FOR ADDITIONAL REQUIREMENTS.
- RIGIDLY SUSPEND UNIT HEATER FROM STRUCTURE WITH SUPPORTING ANGLES AND ALL-THREAD HANGING RODS IN ACCORDANCE WITH MANUFACTURER'S RECOMMENDATIONS.
- PROVIDE EQUIPMENT VENTS AND FLUES PER EQUIPMENT MANUFACTURERS RECOMMENDATIONS AND EQUIPMENT SPECIFICATIONS. KEEP PENETRATIONS THROUGH ROOF A MINIMUM OF 10'-0" FROM HVAC EQUIPMENT FRESH AIR INLETS AND 2'-0" FROM ROOF PARAPETS.
- PROVIDE WALL MOUNTED COVERS AND DAMPERS WITH SUITABLE MOUNTING FRAME TO MATCH WALL CONSTRUCTION. COORDINATE WITH ARCHITECTURAL DRAWINGS.
- PROVIDE A NEW SET OF AIR FILTERS IN UNITS PRIOR TO TESTING, ADJUSTING AND BALANCING AND BEFORE TURNING SYSTEM(S) OVER TO OWNER.

MECHANICAL SYMBOLS

THIS IS A MASTER LEGEND AND NOT ALL SYMBOLS OR ABBREVIATIONS ARE USED.

V3.0

STANDARD MOUNTING HEIGHT	
THERMOSTATS (USER ADJUSTABLE) CONTROLS	46" 46"

INSTALL DEVICES AT THE MOUNTING HEIGHTS SHOWN ABOVE UNO IN THE CONSTRUCTION DOCUMENTS. MOUNTING HEIGHTS LISTED ABOVE OR ELSEWHERE IN THE CONSTRUCTION DOCUMENTS ARE AFF OR AFG TO TOP OF THE DEVICE UNO. ALL DEVICES SHALL BE INSTALLED IN COMPLIANCE WITH CURRENT ADA AND LOCAL REQUIREMENTS.

ANNOTATION	
	MECHANICAL PLAN NOTE CALLOUT
	MECHANICAL EQUIPMENT DESIGNATION (CONTRACTOR FURNISHED AND INSTALLED UNLESS NOTED OTHERWISE)
	CONNECTION POINT OF NEW WORK TO EXISTING
	DETAIL REFERENCE. UPPER NUMBER INDICATES DETAIL NUMBER LOWER NUMBER INDICATES SHEET NUMBER
	SECTION CUT DESIGNATION
	DEDICATED EQUIPMENT ACCESS TILE
	ACCESS PANEL

ABBREVIATIONS			
A/C	AIR CONDITIONING	MIN	MINIMUM
ACC	AIR COOLED CHILLER	N/A	NOT APPLICABLE
ACCU	AIR COOLED CONDENSING UNIT	NC	NORMALLY CLOSED
AFC	ABOVE FINISHED CEILING	N/O	NORMALLY OPEN
AFB	ABOVE FINISHED FLOOR	NO	NOMINAL
AFG	ABOVE FINISHED GRADE	NC	NOISE CRITERIA
AHJ	AUTHORITY HAVING JURISDICTION	NF	NON-FUSED
AHU	AIR HANDLING UNIT	NI	NOT IN CONTRACT
AI	ANALOG INPUT	OA	OUTSIDE AIR
AO	ANALOG OUTPUT	PICV	PRESSURE INDEP. CONTROL VALVE
AP	ACCESS PANEL	PROV	PROVIDE FURNISH AND INSTALL
APR	AIR PRESSURE PROP	QTY	QUANTITY
AWG	AMERICAN WIRE GAUGE	RA	ROOM CRITERIA
B	BOILER	RD	RETURN DUCT
BAS	BUILDING AUTOMATION SYSTEM	REA	RELIEF AIR
BB	BACKBONE	RFR	REFRIGERANT
BD	BACKDRAFT DAMPER	RH	RELATIVE HUMIDITY
BD	BLOWDOWN	RO	ROOF HOOD
BFC	BELOW FINISHED CEILING	RL	REFRIGERANT LIQUID
BFF	BELOW FINISHED FLOOR	RPM	REVOLUTIONS PER MINUTE
BFG	BELOW FINISHED GRADE	RS	REFRIGERANT SUCTION
BFP	BOILER FEED PUMP	RTU	ROOFTOP UNIT
BHP	BRAKE HORSEPOWER	SA	SUPPLY AIR
BI	BINARY INPUT	SCP	STEAM CONDENSATE PUMP
BO	BOTTOM OF STRUCTURE	SCD	SMOKE CONTROL DAMPER
BOD	BOTTOM OF DUCT	SD	SMOKE DETECTOR
BOS	BOTTOM OF STRUCTURE	SD	SUPPLY DUCT
BTU	BRITISH THERMAL UNIT	SF	SUPPLY FAN
CFM	CUBIC FEET PER MINUTE	SH	SENSIBLE HEAT CAPACITY
CH	CHILLER	SOW	SCOPE OF WORK
CLG	COOLING	SP	STATIC PRESSURE
CP	CONDENSATE PUMP	ST	STEAM TRAP
CPT	CONTROL POWER TRANSFORMER	STM	STEAM
CRAC	COMPUTER ROOM AIR CONDITIONING UNIT	TBD	TO BE DETERMINED
CRU	COMPUTER ROOM UNIT	TCIC	TEMPERATURE CONTROLS CONTRACTOR
CT	COOLING TOWER	TCP	TEMPERATURE CONTROL PANEL
CV	CONTROL VALVE	TF	TRANSFER FAN
CWP	CONDENSER	TFA	TO FLOOR ABOVE
CU	CONDENSING UNIT	TFB	TO FLOOR BELOW
CHWP	CHILLED WATER PUMP	TH	TOTAL HEAT CAPACITY
DB	DECIBEL	TSP	TOTAL STATIC PRESSURE
DBA	DECIBEL AVERAGE	TT	TEMPERATURE TRANSMITTAL
DDC	DIRECT DIGITAL CONTROL	TYP	TYPICAL
DI	DIGITAL INPUT	UF	UNDER FLOOR
DISC	DISCONNECT	U/G	UNDERGROUND
DN	DOWN	U/S	UNDERSLAB
DS	DUCT SILENCER	UH	UNIT HEATER
DX	DIRECT EXPANSION	UNO	UNLESS NOTED OTHERWISE
(E)	EXISTING	VAV	VARIABLE AIR VOLUME
EAT	ENTERING AIR	VEL	VELOCITY
EAT	ENTERING	VFD	VARIABLE FREQUENCY DRIVE
ED	AIR TEMPERATURE	VRF	VARIABLE REFRIGERANT FLOW
EDB	ENTERING DRY BULB	VRV	VARIABLE REFRIGERANT VOLUME
EF	EXHAUST FAN	VTR	VENT TO ROOF
EFF	EFFICIENCY	W	WITH
EMS	ENERGY MANAGEMENT SYSTEM	W/O	WITHOUT
ESP	EXTERNAL STATIC PRESSURE	WB	WET BULB
ETR	EXISTING TO REMAIN	WC	WATER COLUMN
EWB	ENTERING WET BULB	WPD	WATER PRESSURE DROP
EWI	ENTERING WATER TEMPERATURE	XP	EXPLOSION PROOF
FCU	FAN COIL UNIT		
FFA	FROM FLOOR ABOVE		
FFB	FROM FLOOR BELOW		
FF	FINISHED FLOOR		
FPI	FINS PER INCH		
FFM	FEET PER MINUTE		
GC	GENERAL CONTRACTOR		
GPM	GALLONS PER MINUTE		
HOA	HAND-OFF AUTOMATIC		
HP	HORSEPOWER		
HTG	HEATING		
HWP	HEATING WATER PUMP		
IN WC	INCHES OF WATER COLUMN		
L	LOUVER		
LAT	LEAVING AIR TEMPERATURE		
LDB	LEAVING DRY BULB		
LP	LOW PRESSURE		
LWB	LEAVING WET BULB		
LWT	LEAVING WATER TEMPERATURE		
MAU	MAKE-UP AIR UNIT		
MAX	MAXIMUM		
MBH	1000 BTU PER HOUR		
MD	MOTORIZED DAMPER		
MFR	MANUFACTURER		

HVAC DUCTWORK AND ACCESSORIES	
	DUCTWORK/EQUIPMENT TO BE REMOVED OR RELOCATED
	EXISTING DUCTWORK/EQUIPMENT TO REMAIN
	LINEAR SLOT DIFFUSER
	CHECK VALVE
	INSULATED FLEXIBLE DUCT (MAX. 5'-0" LONG)
	BRANCH DUCT WITH 45° RECTANGLE ROUND BRANCH FITTING AND MANUAL VOLUME DAMPER
	ELBOW WITH TURNING VANES
	BRANCH DUCT WITH BELL-MOUTH FITTING & MANUAL VOLUME CONTROL DAMPER
	DUCT UP
	DUCT DOWN
	EXHAUST AIR
	EXHAUST AIR - GREASE
	OUTSIDE AIR
	RELIEF AIR
	RETURN AIR
	SPECIAL EXHAUST
	SUPPLY AIR
	EQUIPMENT WITH FLEXIBLE DUCT CONNECTION
	10" (NECK SIZE) CSD-1 (TYPE) 300 CFM (CFM OF SUPPLY DIFFUSER OR REGISTER)
	24x24 (NECK SIZE) CEG-1 (TYPE) 800 CFM (CFM OF EXHAUST GRILLE)
	EQUIPMENT ACCESS TILE (IN ACT CEILINGS)
	ACCESS PANEL (IN GYPSUM)
	DIFFUSER BLANK OFF
	MANUAL VOLUME DAMPER
	SQUARE TO ROUND TRANSITION
	DUCT MOUNTED SMOKE DETECTOR (SD=SUPPLY/RD=RETURN)
	ROUND DUCT TAG INDICATING DIAMETER
	RECTANGULAR DUCT TAG INDICATING INTERNAL DUCT DIMENSIONS.
	FLAT OVAL DUCT TAG INDICATING INTERNAL DUCT DIMENSIONS
	RISER DESIGNATION
	FIRE DAMPER
	FIRE SMOKE DAMPER
	SMOKE DAMPER
	VOLUME DAMPER
	MOTORIZED DAMPER
	BACKDRAFT DAMPER

PIPING SYMBOLS	
	DIRECTION OF FLOW
	CONTROL VALVE
	THREE-WAY CONTROL VALVE
	SHUTOFF VALVE
	CHECK VALVE
	BALANCING VALVE WITH PRESSURE PORTS
	TRIPLE DUTY VALVE WITH PRESSURE PORTS
	STRAINER
	STRAINER WITH BLOWOFF
	RELIEF / SAFETY VALVE
	SOLENOID VALVE
	PRESSURE REDUCING VALVE
	GAS PRESSURE REGULATOR
	THERMOSTATIC MIXING VALVE
	PIPE ANCHOR
	EXPANSION JOINT
	PIPE GUIDE
	PIPING SUPPORT
	F & T TRAP
	BUCKET TRAP
	THERMOSTATIC TRAP
	BACKFLOW PREVENTER
	PRESSURE GAUGE
	THERMOMETER
	PRESSURE AND TEMPERATURE TEST PLUG
	UNION
	FLANGE CONNECTION
	CSD-1 (TYPE) 300 CFM (CFM OF SUPPLY DIFFUSER OR REGISTER)
	VACUUM RELIEF VALVE
	AUTOMATIC AIR VENT
	MANUAL AIR VENT
	PRESSURE / VACUUM SWITCH
	CLEANOUT
	CAP
	ELBOW UP
	ELBOW DOWN
	TEE UP
	TEE DOWN
	ELBOW UP WITH SHUT-OFF VALVE (SOV)
	ELBOW DOWN WITH SHUT-OFF VALVE (SOV)
	TEE UP WITH SHUT-OFF VALVE (SOV)
	TEE DOWN WITH SHUT-OFF VALVE (SOV)
	REDUCER
	RECIRCULATION PUMP
	P-TRAP
	GAS COCK
	TOP BEAM CLAMP
	TRAPEZE HANGER
	FLEXIBLE CONNECTION

PIPING LINETYPES	
	EXISTING PIPING TO BE REMOVED OR RELOCATED
	EXISTING PIPING TO REMAIN
	CONDENSATE DRAIN (CD)
	AUXILIARY CONDENSATE DRAIN (ACD)
	NON-POTABLE WATER (NPW)
	NATURAL GAS (G)
	NATURAL GAS ON ROOF (G)
	MEDIUM PRESSURE NATURAL GAS (MPG)
	MEDIUM PRESSURE NATURAL GAS ON ROOF (MPGR)
	FUEL OIL SUPPLY (FOS)
	FUEL OIL RETURN (FOR)
	FUEL OIL VENT (FOV)
	LIQUEFIED PETROLEUM GAS (LPG)
	BOILER FEED WATER (BFW)
	HIGH PRESSURE STEAM SUPPLY (HPS)
	HIGH PRESSURE STEAM CONDENSATE (HPC)
	LOW PRESSURE STEAM SUPPLY (LPS)
	LOW PRESSURE STEAM CONDENSATE (LPC)
	CONDENSATE PUMP DISCHARGE (CPD)
	HEATING HOT WATER SUPPLY (HWS)
	HEATING HOT WATER RETURN (HWR)
	CHILLED WATER SUPPLY (CHWS)
	CHILLED WATER RETURN (CHWR)
	HOT / CHILLED WATER SUPPLY (HCS)
	HOT / CHILLED WATER RETURN (HCR)
	CONDENSER WATER SUPPLY (CWS)
	CONDENSER WATER RETURN (CWR)
	REFRIGERANT LIQUID (RL)
	REFRIGERANT DISCHARGE (HOT GAS) (RD)
	REFRIGERANT SUCTION (RS)
	REFRIGERANT DISCHARGE BYPASS (RDB)
	REFRIGERANT VENT (RV)

HATCHING LEGEND	
	ENLARGED PLAN
	NOT IN SCOPE (NIS)

LINETYPE LEGEND	
THROUGHOUT THE DRAWINGS DIFFERENT LINETYPES ARE USED IN COMBINATION WITH THE SYMBOLS TO INDICATE THE STATUS OF ITEMS AS EXISTING, TO BE DEMOLISHED, TO BE INCLUDED AS PART OF NEW WORK AND/OR ITEMS WHICH ARE ANTICIPATED TO BE PROVIDED IN THE FUTURE. THE STATUS OF ITEMS USING THESE LINETYPES ARE RELATIVE TO THE VIEW IN WHICH THEY APPEAR. PHASING SHOWN IN DRAWINGS IS NOT INTENDED TO FULLY DESCRIBE ALL NECESSARY CONSTRUCTION PHASING, WHICH IS DETERMINED BY THE CONTRACTOR AS PART OF THEIR RESPONSIBILITIES. ANY SUCH PHASING DESCRIBED IN THE CONSTRUCTION DOCUMENTS ARE GENERAL AND ONLY INTENDED TO INDICATE A BROAD ORDER FOR THE SAKE OF DESCRIBING THE PROJECT. THE FOLLOWING LINETYPES MAY BE USED ON ANY DEVICE, EQUIPMENT, NOTE, LINE, SHAPE, ETC.	
	EXISTING
	DEMOLISH
	NEW
	FUTURE

HVAC CONTROL DEVICES	
	HUMIDISTAT
	THERMOSTAT
	CARBON MONOXIDE SENSOR
	CARBON DIOXIDE SENSOR
	DIFFERENTIAL PRESSURE SENSOR
	FLOW SWITCH
	HUMIDITY SENSOR
	PULL STATION
	REMOTE TESTING STATION WITH INDICATING LIGHT
	STATIC PRESSURE
	TEMPERATURE SENSOR

Sheet List - Mechanical

Sheet Number	Sheet Name	Sheet Order
M000	MECHANICAL GENERAL NOTES AND LEGEND	
M101	HVAC FIRST FLOOR PLAN - OVERALL	
M101A	HVAC FIRST FLOOR PLAN - AREA A	
M101B	HVAC FIRST FLOOR PLAN - AREA B	
M101C	HVAC FIRST FLOOR PLAN - AREA C	
M102	HVAC MEZZANINE PLAN - JAIL	
M103	MECHANICAL ROOF PLAN - OVERALL	
M400	MECHANICAL SCHEDULES	
M401	MECHANICAL SCHEDULES	
M500	MECHANICAL DETAILS	
M600	MECHANICAL CONTROLS	
M601	MECHANICAL CONTROLS	
M602	MECHANICAL CONTROLS	
M603	MECHANICAL CONTROLS	
M604	MECHANICAL CONTROLS	
M605	MECHANICAL CONTROLS	
M606	FIRE-FIGHTER'S CONTROL PANEL	
M6101	MECHANICAL & PLUMBING RISERS	
Grand total: 18		

HMN
architects

7420 W. 110th Street, Suite 200
Overland Park, Kansas 66210
913.451.5075 phone
913.451.5080 fax
hmnarchitects.com

KLINGNER
& ASSOCIATES, P.C.

Engineers • Architects • Surveyors

604 LIBERTY ST., SUITE 125
PELLA, IA 50219
515.612.7402
www.klinger.com

EDGAR COUNTY PUBLIC SAFETY CENTER

MECHANICAL PLAN NOTES:

- M17 INSTALL 3" IPEX UL 1738 PVC PIPING FOR WATER HEATER FLUE AND INTAKE. CONNECT TO WATER HEATER PER MANUFACTURERS RECOMMENDATIONS. ROUTE PIPING THROUGH ROOF.
- M24 MOUNT BAS CONTROL PANEL TO WALL IN THE LOCATION SHOWN.
- M30 INSTALL INDOOR PRESSURE PORT FLUSH WITH CEILING.
- M33 ROUTE DUCT THROUGH THE ROOF TO EXHAUST FAN. INSTALL TRANSITION TO FULL-SIZE FAN CONNECTION IF REQUIRED.



7420 W 110th Street, Suite 200
Overland Park, Kansas 66210
913.451.5075 phone
913.451.5080 fax
hmnarchitects.com

KLINGNER & ASSOCIATES, P.C.
Engineers • Architects • Surveyors

7420 W 110th Street, Suite 200
Overland Park, Kansas 66210
913.451.5075 phone
913.451.5080 fax
hmnarchitects.com

Henderson Engineers
300 S. Central Ave., Suite 300
Chicago, IL 60606
773.462.0900
www.hendersonengineers.com

CHADLER & ASSOCIATES, LLC
300 S. Central Ave., Suite 300
Chicago, IL 60606
773.462.0900
www.chadler.com

EDGAR COUNTY PUBLIC SAFETY CENTER
EDGAR COUNTY, ILLINOIS
12636 950TH ROAD
PARIS, ILLINOIS 61944

21003.003

BID & PERMIT

Architect's Name: _____
License #: XXXXX
Date: 03/01/2024

HENDERSON ENGINEERS
8345 LENEXA DRIVE, SUITE 300
LENEXA, KS 66241
TEL 913.742.9500 FAX 913.742.5001
WWW.HENDERSONENGINEERS.COM

2250004109
IL CORPORATE NO. 184-002965
EXPIRES 4/30/2025



Drawn by: Author
Copyright © 2024 by HMN Architects, Inc.

HVAC FIRST FLOOR PLAN - AREA A

M101.A

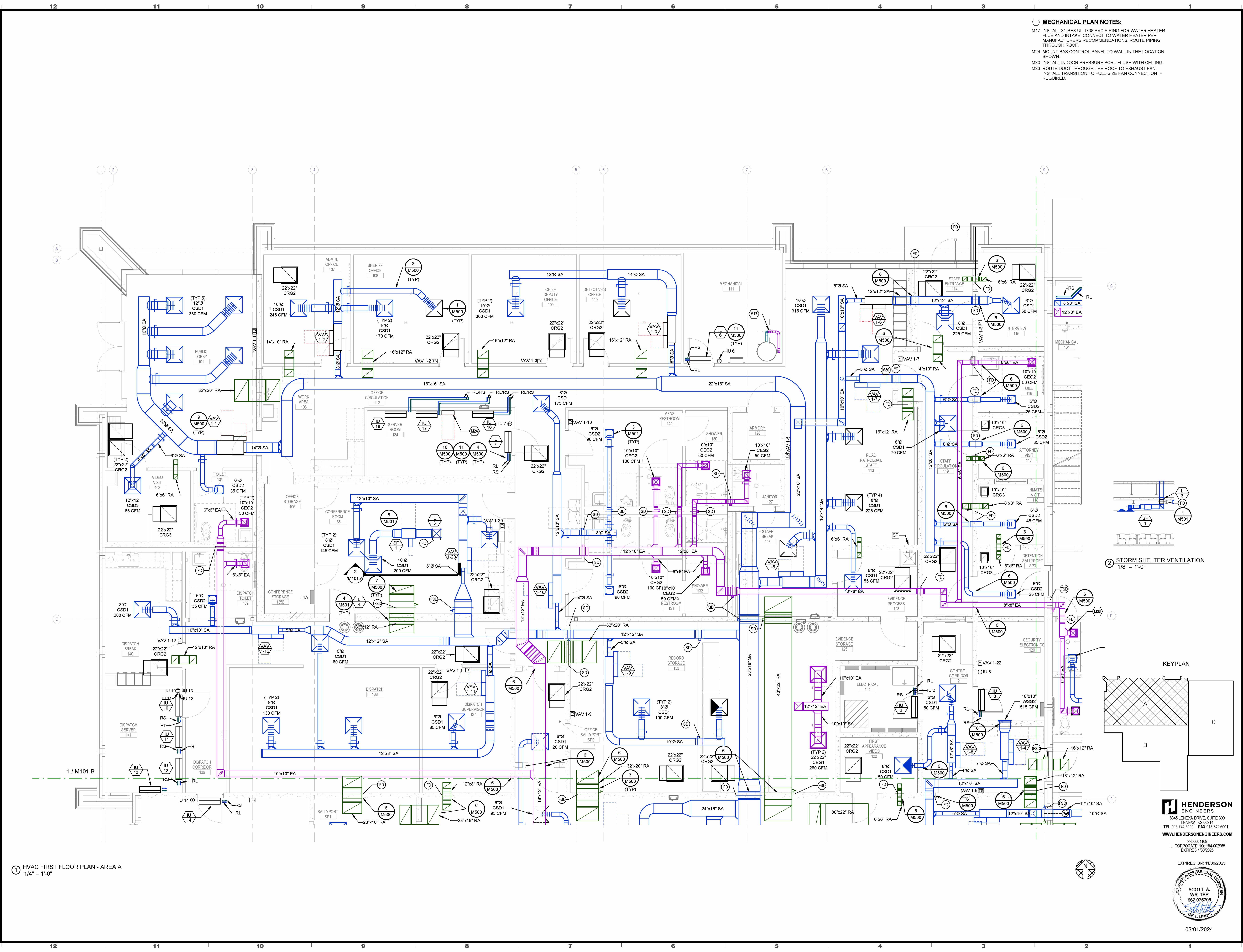

1 HVAC FIRST FLOOR PLAN - AREA A
1/4" = 1'-0"

2 STORM SHELTER VENTILATION
1/8" = 1'-0"

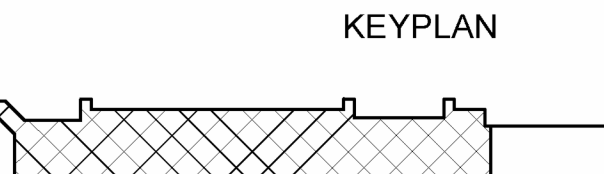

SCOTT A. WALTER

MECHANICAL PLAN NOTES:

- M19 INSTALL 3" IPEX UL 1738 PVC PIPING FOR WATER HEATER FLUE AND INTAKE. CONNECT TO WATER HEATER PER MANUFACTURERS RECOMMENDATIONS AND ROUTE AS SHOWN.
- M20 ROUTE 3" IPEX UL 1738 PVC PIPING TIGHT TO STRUCTURE IN MECHANICAL ROOM AND UP TO FLOOR ABOVE.
- M25 PROVIDE THERMOSTAT WITH VANDAL PROOF COVER PER SPECIFICATIONS.
- M33 ROUTE DUCT THROUGH THE ROOF TO EXHAUST FAN. INSTALL TRANSITION TO FULL-SIZE FAN CONNECTION IF REQUIRED.



7420 W. 110th Street, Suite 200
Overland Park, Kansas 66210
913.451.5075 phone
913.451.5080 fax
hmnarchitects.com

KLINGNER & ASSOCIATES, P.C.
Engineers • Architects • Surveyors
604 LIBERTY ST., SUITE 125
PELLA, IA 50219
515.612.7402
www.klingner.com

HENDERSON ENGINEERS
1200 N. CENTRAL AVENUE, SUITE 300
CHICAGO, ILLINOIS 60642
312.467.0900
www.hendersonengineers.com

BID & PERMIT

EDGAR COUNTY PUBLIC SAFETY CENTER
EDGAR COUNTY, ILLINOIS
12636 950TH ROAD
PAFIS, ILLINOIS 61944

21003.003

BID & PERMIT

Architect's Name
License # XXXXX
Date: 03/01/2024

HENDERSON ENGINEERS
8345 LEXENA DRIVE, SUITE 300
LENEXA, KS 66214
TEL. 913.742.9500 FAX 913.742.5001
WWW.HENDERSONENGINEERS.COM

2250004109
IL CORPORATE NO. 184-002985
EXPIRES 4/30/2026



EXPIRES ON: 11/30/2025

Drawn by: Author
Copyright © 2024 by HMN Architects, Inc.

HVAC FIRST FLOOR PLAN - AREA C

M101.C

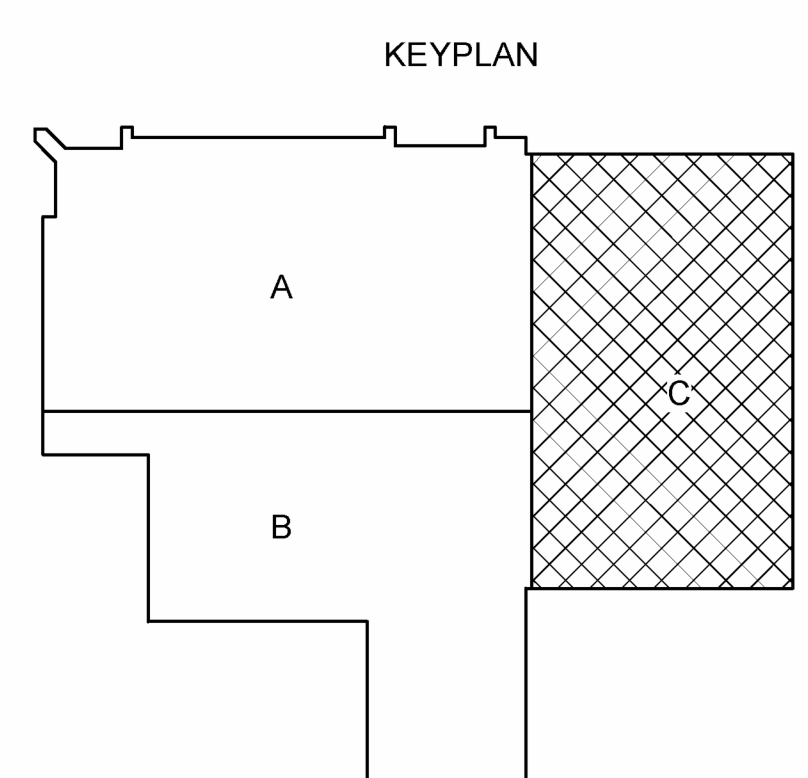
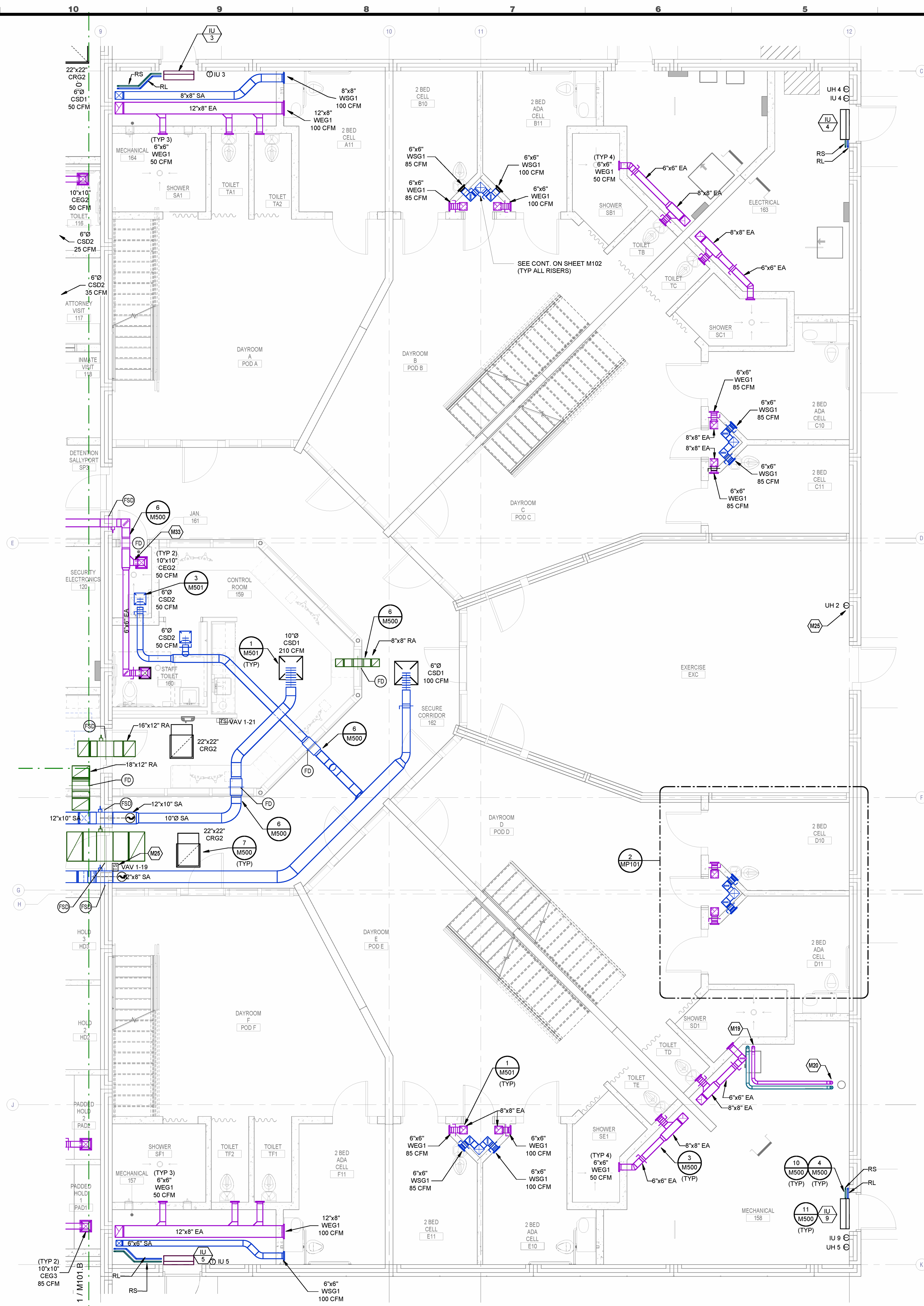

1 HVAC FIRST FLOOR PLAN - AREA C
1/4" = 1'-0"



SCOTT A. WALTER

ROOFTOP UNIT SCHEDULE (DX COOLING, NATURAL GAS HEAT)

MARK	MANUFACTURER	MODEL	UNIT TYPE	SUPPLY FAN										EXHAUST FAN										COOLING COIL										GAS FIRED HEAT EXCHANGER										ELECTRICAL				WEIGHT (LBS)	NOTES
				FAN TYPE	CFM	ESP (IN)	BHP (EACH)	NOM HP (EACH)	VFD (Y/N)	FAN TYPE	CFM	ESP (IN)	BHP (EACH)	NOM HP (EACH)	VFD (Y/N)	TH (MBH)	SH (MBH)	EAT (°F DB)	LAT (°F WB)	REFR TYPE	MIN EFF (EER)	MIN NO STAGES	MAX VEL (FPM)	MIN OUT (MBH)	NOM INPUT (MBH)	EAT (°F DB)	LAT (°F WB)	MIN NO STAGES	MAX VEL (FPM)	MIN DA (CFM)	VIPH	MCA	MOCP	DISC TYPE															
RTU-1	GREENHECK	RV-75	MULTI-ZONE	PLENUM	8,800	1.8	2	2.06	3.0	3.0	Y	PLENUM	8,800	0.5	2	0.38	1.5	Y	373.1	219.7	77.6	67.0	55	53.5	R410A	11	15.7	VARIABLE	550	209.1	600	80	38	35.9	16	550	0	4603	62.5	80	NF	7275	A-R						

MODEL NUMBERS AND NOMINAL TONS LISTED SHALL NOT BE CONSIDERED COMPLETE AND MATERIAL SHALL NOT BE ORDERED BY MANUFACTURER, MODEL NUMBERS, OR NOMINAL TONS ONLY. REVIEW THE COMPLETE DESCRIPTION, NOTES AND SPECIFICATIONS TO DETERMINE THE EXACT MATERIAL AND ACCESSORIES TO BE ORDERED. THE MANUFACTURERS LISTED ARE THE BASIS FOR THE DESIGN.

- NOTES:
- A. REFER TO SHEET M001 FOR PACKAGED MULTI-ZONE VAV ROOFTOP UNIT CONTROL DRAWING, POINTS LIST, AND SEQUENCE.
 - B. EQUIPMENT SIZED FOR 100°F AMBIENT TEMPERATURE.
 - C. PROVIDE 2" MERV 13 EFFICIENT PLEATED THROWAWAY AIR FILTERS.
 - D. PROVIDE FACTORY MOUNTED DISCONNECT INSTALLED ON SERVICE SIDE OF UNIT.
 - E. STARTERS FOR ALL MOTORS SHALL BE FURNISHED INTEGRAL WITH UNIT.
 - F. PROVIDE FACTORY MOUNTED VARIABLE FREQUENCY DRIVE TO FACILITATE MODULATING FAN SPEED CONTROL.
 - G. PROVIDE SHAFT GROUNDING SYSTEM ON MOTOR. REFER TO MOTOR SPECIFICATION FOR ADDITIONAL INFORMATION.
 - H. PROVIDE SINGLE POINT POWER CONNECTION.
 - J. COORDINATE SIZE OF CONDUCTOR TERMINATION LUGS WITH CONDUCTOR SIZES SHOWN ON ELECTRICAL DRAWINGS.
 - K. PROVIDE 125 VAC, 20 AMP DUPLEX CONVENIENCE RECEPTACLE MOUNTED TO UNIT READY FOR FIELD WIRING WITH A COVER UL LISTED FOR WET AND DAMPER LOCATIONS WHEN IN USE.
 - L. SPECIFIED FAN ESP ACCOUNTS FOR DUCT LOSSES EXTERNAL TO UNIT.
 - M. PROVIDE MOTOR HORSEPOWER TO OVERCOME INTERNAL UNIT STATIC PRESSURE DROP PLUS SPECIFIED EXTERNAL STATIC PRESSURE DROP. NOMINAL MOTOR HP SHALL BE NO LARGER THAN THE FIRST AVAILABLE NOMINAL MOTOR SIZE GREATER THAN THE REQUIRED BHP.
 - N. PROVIDE INSULATED ROOF CURB WITH MINIMUM HEIGHT REQUIRED TO MAINTAIN BOTTOM OF EQUIPMENT A MINIMUM OF 16 INCHES ABOVE FINISHED ROOF SURFACE. PROVIDE SLOPED CURB IF NEEDED TO MATCH ROOF SLOPE.
 - O. COORDINATE WITH ROOF INSULATION THICKNESS AND ROOF TAPER AT INSTALLED LOCATION. COORDINATE CURB TYPE WITH DRAWINGS.
 - P. SCHEDULED WEIGHT IS THE MAXIMUM ALLOWABLE OPERATING WEIGHT OF THE EQUIPMENT AND CURB.
 - Q. COOLING COIL LAT IS LEAVING AIR TEMPERATURE OF COIL.
 - R. PROVIDE GUARDS TO PROTECT CONDENSER COIL FROM HAIL OR OTHER DAMAGE.
 - S. COOLING COIL SHALL BE CAPABLE OF MODULATING CAPACITY WITHOUT THE USE OF HOT GAS BYPASS. PROVIDE VARIABLE SPEED LEAD COMPRESSOR FOR CAPACITY CONTROL.

100% OUTDOOR AIR UNIT - ROOFTOP UNIT W/ ENERGY RECOVERY (DX COOLING, NATURAL GAS HEATING)

MARK	MANUFACTURER	MODEL	UNIT TYPE	SUPPLY FAN										EXHAUST FAN										SUMMER HEAT RECOVERY										COOLING COIL										WINTER HEAT RECOVERY										GAS FIRED HEAT EXCHANGER										ELECTRICAL				WEIGHT (LBS)	NOTES
				FAN TYPE	DESIGN CFM	MINIMUM CFM	ESP (IN)	BHP (Y/N)	NOM HP (Y/N)	VFD (Y/N)	FAN TYPE	DESIGN CFM	MINIMUM CFM	ESP (IN)	BHP (Y/N)	NOM HP (Y/N)	VFD (Y/N)	MAX ENERGY RECOVERY PRESS DROP (IN)	MIN ENTHALPY RECOVERY RATIO (%)	OAT (°F DB)	EXHAUST EAT (°F DB)	SUPPLY LAT (°F WB)	REFR TYPE	TH (MBH)	SH (MBH)	EAT (°F DB)	LAT (°F WB)	MIN EFF (ISMRE)	MIN NO STAGES	MAX VEL (FPM)	OAT (°F DB)	EXHAUST EAT (°F DB)	SUPPLY LAT (°F WB)	MIN OUT (MBH)	NOM INPUT (MBH)	MIN EFF (%)	EAT (°F DB)	LAT (°F WB)	MIN NO STAGES	MAX VEL (FPM)	VIPH	MCA	MOCP	DISC TYPE																									
RTU-2	GREENHECK	RVE-40	SINGLE ZONE	PLENUM	2,915	2,915	1.3	2.0	3.0	Y	PLENUM	2,400	2,400	0.8	1.2	1.5	Y	0.89	50	87.2	78.8	69.0	57.6	79.3	69.3	R410A	134.1	78.3	79.3	69.3	55.0	55.0	5.2	VARIABLE	550	-0.5	74.0	61.7	41.4	39.6	137.3	200	95.0	41.4	85.0	16	600	4603	31	45	NF	3660	A-U																
RTU-3	GREENHECK	RVE-40	SINGLE ZONE	PLENUM	2,915	2,915	1.3	2.0	3.0	Y	PLENUM	2,400	2,400	0.8	1.2	1.5	Y	0.89	50	87.2	78.8	69.0	57.6	79.3	69.3	R410A	134.1	78.3	79.3	69.3	55.0	55.0	5.2	VARIABLE	550	-0.5	74.0	61.7	41.4	39.6	137.3	200	95.0	41.4	85.0	16	600	4603	31	45	NF	3660	A-U																

MODEL NUMBERS AND NOMINAL TONS LISTED SHALL NOT BE CONSIDERED COMPLETE AND MATERIAL SHALL NOT BE ORDERED BY MANUFACTURER, MODEL NUMBERS, OR NOMINAL TONS ONLY. REVIEW THE COMPLETE DESCRIPTION, NOTES AND SPECIFICATIONS TO DETERMINE THE EXACT MATERIAL AND ACCESSORIES TO BE ORDERED. THE MANUFACTURERS LISTED ARE THE BASIS FOR THE DESIGN.

- NOTES:
- A. REFER TO ROOFTOP UNIT CONTROL MATRIX FOR ADDITIONAL UNIT FEATURES, COMPONENTS, MODULES, ACCESSORIES, AND CONTROLS THAT SHALL BE PROVIDED WITH THE EQUIPMENT.
 - B. EQUIPMENT SIZED FOR 100°F AMBIENT TEMPERATURE.
 - C. PROVIDE 2" MERV 13 EFFICIENT PLEATED THROWAWAY AIR FILTERS.
 - D. PROVIDE FACTORY MOUNTED DISCONNECT INSTALLED ON SERVICE SIDE OF UNIT.
 - E. STARTERS FOR ALL MOTORS SHALL BE FURNISHED INTEGRAL WITH UNIT.
 - F. PROVIDE FACTORY MOUNTED VARIABLE FREQUENCY DRIVE TO FACILITATE MODULATING FAN SPEED CONTROL.
 - G. PROVIDE SHAFT GROUNDING SYSTEM ON FAN MOTOR. REFER TO MOTOR SPECIFICATION FOR ADDITIONAL INFORMATION.
 - H. PROVIDE SINGLE POINT POWER CONNECTION.
 - J. COORDINATE SIZE OF CONDUCTOR TERMINATION LUGS WITH CONDUCTOR SIZES SHOWN ON ELECTRICAL DRAWINGS.
 - K. PROVIDE 125 VAC, 20 AMP DUPLEX CONVENIENCE RECEPTACLE MOUNTED TO UNIT READY FOR FIELD WIRING WITH A COVER UL LISTED FOR WET AND DAMPER LOCATIONS WHEN IN USE.
 - L. SPECIFIED FAN ESP ACCOUNTS FOR DUCT LOSSES EXTERNAL TO UNIT.
 - M. PROVIDE MOTOR HORSEPOWER TO OVERCOME INTERNAL UNIT STATIC PRESSURE DROP PLUS SPECIFIED EXTERNAL STATIC PRESSURE DROP. NOMINAL MOTOR HP SHALL BE NO LARGER THAN THE FIRST AVAILABLE NOMINAL MOTOR SIZE GREATER THAN THE REQUIRED BHP.
 - N. PROVIDE INSULATED ROOF CURB WITH MINIMUM HEIGHT REQUIRED TO MAINTAIN BOTTOM OF EQUIPMENT A MINIMUM OF 16 INCHES ABOVE FINISHED ROOF SURFACE. PROVIDE SLOPED CURB IF NEEDED TO MATCH ROOF SLOPE.
 - O. COORDINATE WITH ROOF INSULATION THICKNESS AND ROOF TAPER AT INSTALLED LOCATION. COORDINATE CURB TYPE WITH DRAWINGS.
 - P. SCHEDULED WEIGHT IS THE MAXIMUM ALLOWABLE OPERATING WEIGHT OF THE EQUIPMENT AND CURB.
 - Q. COOLING COIL LAT IS LEAVING AIR TEMPERATURE OF COIL.
 - R. PROVIDE HEATER TO MEET OR EXCEED SCHEDULED MINIMUM MBH OUTPUT. NOMINAL INPUT IS BASED ON LISTED MANUFACTURER'S STANDARD PRODUCT. COORDINATE EQUIPMENT GAS LOAD WITH PLUMBING CONTRACTOR IF DIFFERENT FROM THAT SCHEDULED. MEET MINIMUM EFFICIENCY SCHEDULED.
 - S. PROVIDE GUARDS TO PROTECT CONDENSER COIL FROM HAIL OR OTHER DAMAGE.
 - T. PROVIDE DEFROST CONTROL FOR THE ENERGY RECOVERY DEVICE.
 - U. PROVIDE HOT GAS REHEAT COIL.

ENERGY RECOVERY VENTILATION UNIT SCHEDULE

MARK	MANUFACTURER	MODEL	SUPPLY FAN										EXHAUST FAN										SUMMER SUPPLY										WINTER EXHAUST										WINTER SUPPLY										ELECTRICAL				WEIGHT (LBS)	NOTES
			FAN TYPE	OA (CFM)	ESP (IN)	BHP (Y/N)	NOM HP (Y/N)	VFD (Y/N)	FAN TYPE	EXH (CFM)	ESP (IN)	BHP (Y/N)	NOM HP (Y/N)	VFD (Y/N)	EAT (°F DB)	LAT (°F WB)	REFR TYPE	TH (MBH)	SH (MBH)	EAT (°F DB)	LAT (°F WB)	MIN EFF (%)	MIN NO STAGES	MAX VEL (FPM)	OAT (°F DB)	EXHAUST EAT (°F DB)	SUPPLY LAT (°F WB)	REFR TYPE	TH (MBH)	SH (MBH)	EAT (°F DB)	LAT (°F WB)	MIN EFF (%)	MIN NO STAGES	MAX VEL (FPM)	VIPH	MCA	MOCP	DISC TYPE	STARTER TYPE																		
ERV-1	GREENHECK	ERV-90	FC	4,750	1.00	3.5	5	Y	FC	2,915	1.15	1.9	2	Y	74	61.7	86.1	76.8	87.2	78.8	79	69.5	69	57.6	7.5	7.4	0.5	-1.1	40.9	38.2	4603	14.9	20	NF	COMBO	3500	A-G																					

MODEL NUMBERS SHALL NOT BE CONSIDERED COMPLETE AND MATERIAL SHALL NOT BE ORDERED BY MANUFACTURER AND MODEL NUMBERS ONLY. REVIEW THE COMPLETE DESCRIPTION, NOTES AND SPECIFICATIONS TO DETERMINE THE EXACT MATERIAL AND ACCESSORIES TO BE ORDERED. THE MANUFACTURERS LISTED ARE THE BASIS FOR THE DESIGN.

- NOTES:
- A. PROVIDE 2" MERV 8 PLEATED THROWAWAY AIR FILTERS IN EACH AIRSTREAM.
 - B. PROVIDE FACTORY MOUNTED DISCONNECT INSTALLED ON SERVICE SIDE OF UNIT.
 - C. STARTER(S) PROVIDED BY DIVISION 26 CONTRACTOR.
 - D. PROVIDE INSULATED ROOF CURB WITH MINIMUM HEIGHT REQUIRED TO MAINTAIN BOTTOM OF EQUIPMENT A MINIMUM OF 16 INCHES ABOVE FINISHED ROOF SURFACE. PROVIDE SLOPED CURB IF NEEDED TO MATCH ROOF SLOPE.
 - E. COORDINATE WITH ROOF INSULATION THICKNESS AND ROOF TAPER AT INSTALLED LOCATION. COORDINATE CURB TYPE WITH DRAWINGS.
 - F. SCHEDULED WEIGHT IS THE MAXIMUM ALLOWABLE OPERATING WEIGHT OF THE EQUIPMENT AND CURB.
 - G. PROVIDE DEFROST CONTROL.

ELECTRIC DUCT HEATER SCHEDULE

MARK	MANUFACTURER	MODEL	MIN OUT (MBH)	NOM INPUT (KW)	MIN NO OF STAGES	SIZE (W x H)	MAX APD (IN)	CFM	MAX TEMP RISE (°F)	DISC TYPE	VIPH	NOTES
DH-1	GREENHECK	IDHE-O	88	30	SCR	26" X 20"	0.1	4750	17	FUSED	4803	A-H

MODEL NUMBERS SHALL NOT BE CONSIDERED COMPLETE AND MATERIAL SHALL NOT BE ORDERED BY MANUFACTURER AND MODEL NUMBERS ONLY. REVIEW THE COMPLETE DESCRIPTION, NOTES AND SPECIFICATIONS TO DETERMINE THE EXACT MATERIAL AND ACCESSORIES TO BE ORDERED. THE MANUFACTURERS LISTED ARE THE BASIS FOR THE DESIGN.

- NOTES:
- A. UNIT AIR PRESSURE DROP SHALL NOT EXCEED SCHEDULED VALUE.
 - B. SUPPORT UNIT FROM STRUCTURE WITH ALL-THREAD HANGING RODS.
 - C. PROVIDE FACTORY MOUNTED DISCONNECT INSTALLED ON SERVICE SIDE OF UNIT.
 - D. PROVIDE AIRFLOW PROVING SWITCH AND THERMAL OVERLOAD PROTECTION.
 - E. PROVIDE MAGNETIC CONTACTORS.
 - F. PROVIDE SCR CONTROLS DESIGNED TO MODULATE THE HEATER OUTPUT FROM 0 TO 100 PERCENT CAPACITY.
 - G. PROVIDE CONTROL POWER TRANSFORMER AND LOW VOLTAGE THERMOSTAT WITH STAGES AS REQUIRED TO CONTROL HEATER.
 - H. PROVIDE PRESSURE PLATE TO ENSURE UNIFORM AIRFLOW ACROSS HEATER.

FAN SCHEDULE

MARK	SERVICE DESCRIPTION	MANUFACTURER	MOUNTING	MODEL	CFM	ESP (IN)	BHP (Y/N)	NOM HP (Y/N)	FAN RPM	DRIVE (BELT/DIRECT)	VFD (Y/N)	VIPH	DISC TYPE	STARTER TYPE	WEIGHT (LBS)	NOTES
EF-1	POLLUTION EXHAUST	GREENHECK	ROOF	CUE-100-VG	1175	0.5	0.16	1.4	1131	DIRECT	N	115V	ECM	ECM	75	A, B, G
EF-2	EXHAUST	GREENHECK	ROOF	CUE-090-VG	960	0.5	0.09	1.4	1254	DIRECT	N	115V	ECM	ECM	75	A, B, G
EF-3	EXHAUST	GREENHECK	ROOF	CUE-090-VG	400	0.5	0.09	1.4	1254	DIRECT	N	115V	ECM	ECM	75	A, B, G
EF-4	EXHAUST	GREENHECK	ROOF	CUE-090-VG	340	0.5	0.08	1.4	1407	DIRECT	N	115V	ECM	ECM	75	A, B, G
EF-5	MINIMUM EXHAUST	GREENHECK	ROOF	CUE-090-VG	125	0.4	0.03	1.0	1291	DIRECT	N	115V	ECM	ECM	35	A, B, G
SEF-1	SMOKE EXHAUST	GREENHECK	ROOF	CUBE	1550	0.5	0.32	1.0	1492	BELT	N	115V	NF	COMBINATION	100	A, C, D, E, F, H, K
SEF-2	SMOKE EXHAUST	GREENHECK	ROOF	CUBE	1860	0.5	0.31	1.0	911	BELT	N	115V	NF	COMBINATION	120	A, C, D, E, F, H, K
SEF-3	SMOKE EXHAUST	GREENHECK	ROOF	CUBE	1785	0.5	0.28	1.0	758	BELT	N	115V	NF	COMBINATION	160	A, C, D, E, F, H, K
SEF-4	SMOKE EXHAUST	GREENHECK	ROOF	CUBE	1785	0.5	0.28	1.0	758	BELT	N	115V	NF	COMBINATION	160	A, C, D, E, F, H, K
SEF-5	SMOKE EXHAUST	GREENHECK	ROOF	CUBE	1660	0.5	0.31	1.0	911	BELT	N	115V	NF	COMBINATION	120	A, C, D, E, F, H, K
SEF-6	SMOKE EXHAUST	GREENHECK	ROOF	CUBE	1745	0.5	0.29	1.0	884	BELT	N	115V	NF	COMBINATION	120	A, C, D, E, F, H, K
SEF-7	SMOKE EXHAUST	GREENHECK	ROOF	CUBE	2490	0.5	0.45	1.2	700	BELT	N	115V	NF	COMBINATION	145	A, C, D, E, F, H, K
SF-1	SHELTER SUPPLY	GREENHECK	INLINE	SQ	130	0.75	0.12	1.4	1590	DIRECT	N	115V	ECM	ECM	50	G, J

MODEL NUMBERS SHALL NOT BE CONSIDERED COMPLETE AND MATERIAL SHALL NOT BE ORDERED BY MANUFACTURER AND MODEL NUMBERS ONLY. REVIEW THE COMPLETE DESCRIPTION, NOTES AND SPECIFICATIONS TO DETERMINE THE EXACT MATERIAL AND ACCESSORIES TO BE ORDERED. THE MANUFACTURERS LISTED ARE THE BASIS FOR THE DESIGN.

- NOTES:
- A. PROVIDE INSULATED ROOF CURB WITH MINIMUM HEIGHT REQUIRED TO MAINTAIN BOTTOM OF EQUIPMENT A MINIMUM OF 16 INCHES ABOVE FINISHED ROOF SURFACE. PROVIDE SLOPED CURB IF NEEDED TO MATCH ROOF SLOPE.
 - B. COORDINATE WITH ROOF INSULATION THICKNESS AND ROOF TAPER AT INSTALLED LOCATION. COORDINATE CURB TYPE WITH DRAWINGS.
 - C. PROVIDE BIRDSCREEN AND GRAVITY BACKDRIFT DAMPER.
 - D. PROVIDE FACTORY MOUNTED DISCONNECT SWITCH.
 - E. PROVIDE FACTORY MOUNTED MOTOR STARTER.
 - F. FAN SHALL BE SELECTED FOR STABLE OPERATION AT ELEVATED TEMPERATURE OF 350 F.
 - G. FANS USED FOR SMOKE CONTROL SHALL HAVE 1.5 TIMES THE NUMBER OF BELTS REQUIRED FOR THE DESIGN DUTY.
 - H. PROVIDE WITH MANUFACTURER'S ELECTRONICALLY COMMUTATED (EC) MOTOR.
 - I. PROVIDE WITH AUXILIARY CONTACTS FOR SHUTDOWN UPON NOTIFICATION FROM FIRE ALARM SYSTEM.
 - J. PROVIDE WITH SPRING VIBRATION ISOLATION AND ALL-THREAD HANGING RODS.
 - K. PROVIDE BIRDSCREEN AND MOTORIZED DAMPER.

UNIT HEATER SCHEDULE (NATURAL GAS)

MARK	MANUFACTURER	MODEL	MIN OUT (MBH)	MIN EFF (%)	GAS VALVE	CFM	MOTOR HP	THROW (FT)	VIPH	MOCP	DISC TYPE	NOTES
UH-1	REZNOR	UDX-150	120.27	83	2-STAGE	1620	0.25	30	115V	15	NF	A,F
UH-2	REZNOR	UDX-050	48.23	83	2-STAGE	770	0.03	30	115V	15	NF	A,F

MODEL NUMBERS SHALL NOT BE CONSIDERED COMPLETE AND MATERIAL SHALL NOT BE ORDERED BY MANUFACTURER AND MODEL NUMBERS ONLY. REVIEW THE COMPLETE DESCRIPTION, NOTES AND SPECIFICATIONS TO DETERMINE THE EXACT MATERIAL AND ACCESSORIES TO BE ORDERED. THE MANUFACTURERS LISTED ARE THE BASIS FOR THE DESIGN.

- NOTES:
- A. SEE PLANS FOR MOUNTING HEIGHTS.
 - B. PROVIDE WITH WALL MOUNTED THERMOSTAT.
 - C. PROVIDE NECESSARY MOUNTING BRACKET AND ACCESSORIES FOR HORIZONTAL MOUNTING.
 - D. PROVIDE FACTORY MOUNTED DISCONNECT INSTALLED ON SERVICE SIDE OF UNIT.
 - E. PROVIDE WITH ALUMINUM STEEL HEAT EXCHANGER.
 - F. PROVIDE ELECTRONIC OPERATED GAS CONTROL VALVE.

UNIT HEATER SCHEDULE (ELECTRIC)

MARK	MANUFACTURER	MODEL	MIN OUT (MBH)	NOM HP	MIN NO OF STAGES	CFM	VIPH	DISC TYPE	NOTES
UH-3	REZNOR	EGS	16	5	1	310	208V	NF	A, B, C
UH-4	REZNOR	EUH	7	3	1	300	208V	NF	A, B, C
UH-5	REZNOR	EUH	7	3	1	300	208V	NF	A, B, C

MODEL NUMBERS SHALL NOT BE CONSIDERED COMPLETE AND MATERIAL SHALL NOT BE ORDERED BY MANUFACTURER AND MODEL NUMBERS ONLY. REVIEW THE COMPLETE DESCRIPTION, NOTES AND SPECIFICATIONS TO DETERMINE THE EXACT MATERIAL AND ACCESSORIES TO BE ORDERED. THE MANUFACTURERS LISTED ARE THE BASIS FOR THE DESIGN.

- NOTES:
- A. PROVIDE WITH WALL MOUNTED THERMOSTAT.
 - B. PROVIDE NECESSARY MOUNTING BRACKET AND ACCESSORIES FOR CEILING MOUNTING.
 - C. PROVIDE FACTORY MOUNTED DISCONNECT INSTALLED ON SERVICE SIDE OF UNIT.



7400 W 110th Street, Suite 200
Overland Park, Kansas 66210
913.451.5075 phone
913.451.5080 fax
hmnarchitects.com

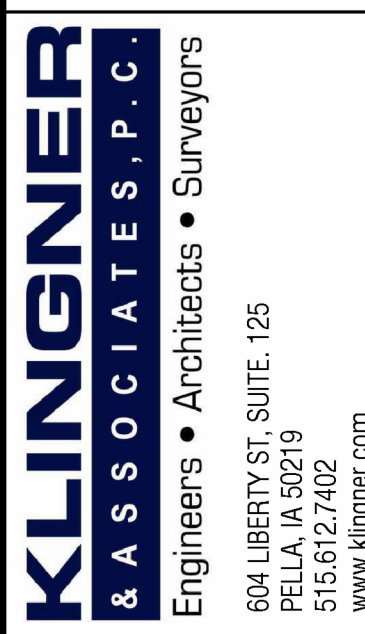

Henderson Engineers
300 N. Central Ave., Ste. 1113, 65201
Channahon, IL 61515
946.244.2200
946.244.2201
www.klinger.com

604 LIBERTY ST. SUITE 125
PELLA, IA 50228
515.612.7402
www.klinger.com

BID & PERMIT

EDGAR COUNTY PUBLIC SAFETY CENTER
EDGAR COUNTY, ILLINOIS
12636 950TH ROAD
PAFIS, ILLINOIS 61944
21003.003

BID & PERMIT

Architect's Name
License # XXXXX
Date: 03/01/2024



8345 LENEVA DRIVE, SUITE 300
LENEVA, IL 62424
TEL 913.742.9500 FAX 913.742.5001
WWW.HENDERSONENGINEERS.COM

225004109
IL CORPORATE NO. 184-002965
EXPIRES 4/30/2026

EXPIRES ON: 11/30/2025

SCOTT A. WALTER
Professional Engineer
No. 062.075705
State of Illinois

Drawn by: Author
Copyright © 2024 by HMN Architects, Inc.

MECHANICAL SCHEDULES

M400

03/01/2024

SCOTT A. WALTER

MARK	INLET SIZE (IN)	PRIMARY (CFM)	MIN PRIM (CFM)	MIN HEAT (CFM)	MAX HEAT					HEATING COIL					CP TRANS			ELECTRICAL			SOUND POWER		CONTROL TYPE	NOTES
					VEAT (CFM)	LAT (°F)	MBH	NOM KW	STEPS	HTG CTRL	INTEGRAL	V/PH	MCA	MOCP	RADIATED	DISCHARGE	INTEGRAL	V/PH	MCA	MOCP	RADIATED	DISCHARGE		
VAV-1-1	14	2000	1200	1200	1200	55	85.0	38.9	12.0	-	SCR	INTEGRAL	480V/3PH/4W	18.70	20	57.51, 45.37, 33.32	66.60, 60.64, 52.49	SINGLE MAX SINGLE MIN	A-L					
VAV-1-2	8	585	293	293	293	55	85.0	9.5	3.0	-	SCR	INTEGRAL	277V/1PH	13.80	15	36.49, 39.34, 29.24	71.63, 54.51, 47.43	SINGLE MAX SINGLE MIN	A-L					
VAV-1-3	8	600	300	300	300	55	85.0	9.7	3.0	-	SCR	INTEGRAL	277V/1PH	13.80	15	39.51, 44.35, 29.29	74.67, 57.52, 48.46	SINGLE MAX SINGLE MIN	A-L					
VAV-1-5	12	1215	608	608	608	55	80.0	16.4	5.0	-	SCR	INTEGRAL	277V/1PH	23.60	25	59.52, 48.41, 35.28	74.66, 60.59, 54.50	SINGLE MAX SINGLE MIN	A-L					
VAV-1-6	5	275	110	110	110	55	84.0	3.4	1.5	-	SCR	INTEGRAL	277V/1PH	4.90	15	63.58, 46.39, 34.31	81.77, 63.98, 53.48	SINGLE MAX SINGLE MIN	A-L					
VAV-1-7	5	200	99	99	99	55	80.0	2.7	1.0	-	SCR	INTEGRAL	277V/1PH	3.90	15	59.53, 41.36, 31.29	76.71, 57.53, 49.45	SINGLE MAX SINGLE MIN	A-L					
VAV-1-8	4	100	45	45	45	55	85.0	1.5	0.5	-	SCR	INTEGRAL	277V/1PH	2.50	15	46.41, 31.27, 24.24	64.98, 47.43, 41.37	SINGLE MAX SINGLE MIN	A-L					
VAV-1-9	5	200	99	99	99	55	80.0	3.2	1.0	-	SCR	INTEGRAL	277V/1PH	4.40	15	59.53, 41.36, 31.29	76.71, 57.53, 49.45	SINGLE MAX SINGLE MIN	A-L					
VAV-1-10	6	355	142	142	142	55	80.0	3.8	1.5	-	SCR	INTEGRAL	277V/1PH	5.40	15	67.63, 50.43, 37.33	85.81, 66.62, 57.51	SINGLE MAX SINGLE MIN	A-L					
VAV-1-11	7	425	170	170	170	55	80.0	5.5	2.0	-	SCR	INTEGRAL	277V/1PH	7.90	15	64.57, 47.40, 35.30	78.73, 63.97, 51.48	SINGLE MAX SINGLE MIN	A-L					
VAV-1-12	5	235	100	100	100	55	83.0	3.0	1.0	-	SCR	INTEGRAL	277V/1PH	4.40	15	61.56, 44.36, 33.30	78.74, 60.56, 51.47	SINGLE MAX SINGLE MIN	A-L					
VAV-1-13	12	1515	758	758	758	55	80.0	20.5	6.0	-	SCR	INTEGRAL	277V/1PH	29.50	30	61.53, 46.36, 33.29	74.67, 59.58, 53.50	SINGLE MAX SINGLE MIN	A-L					
VAV-1-14	4	155	75	75	75	55	84.0	2.4	1.0	-	SCR	INTEGRAL	277V/1PH	3.40	15	55.49, 38.33, 29.27	72.65, 53.50, 46.42	SINGLE MAX SINGLE MIN	A-L					
VAV-1-15	4	110	52	52	52	55	80.0	1.4	0.5	-	SCR	INTEGRAL	277V/1PH	2.50	15	51.43, 33.28, 25.25	66.60, 48.45, 42.38	SINGLE MAX SINGLE MIN	A-L					
VAV-1-16	9	805	403	403	403	55	80.0	10.9	3.5	-	SCR	INTEGRAL	277V/1PH	15.70	20	60.53, 43.38, 31.26	75.67, 59.58, 50.46	SINGLE MAX SINGLE MIN	A-L					
VAV-1-17	6	330	132	132	132	55	80.0	3.6	1.5	-	SCR	INTEGRAL	277V/1PH	4.90	15	66.62, 49.42, 36.33	84.80, 65.61, 56.51	SINGLE MAX SINGLE MIN	A-L					
VAV-1-18	6	285	114	114	114	55	85.0	3.7	1.5	-	SCR	INTEGRAL	277V/1PH	5.40	15	64.59, 47.40, 35.32	82.77, 63.98, 54.49	SINGLE MAX SINGLE MIN	A-L					
VAV-1-19	5	200	80	80	80	55	85.0	2.6	1.0	-	SCR	INTEGRAL	277V/1PH	3.90	15	53.45, 37.30, 28.24	67.61, 52.48, 44.41	SINGLE MAX SINGLE MIN	A-L					
VAV-1-20	6	285	114	114	114	55	80.0	3.1	1.0	-	SCR	INTEGRAL	277V/1PH	4.40	15	56.49, 40.35, 31.27	69.63, 54.49, 43.41	SINGLE MAX SINGLE MIN	A-L					
VAV-1-21	5	210	84	84	84	55	80.0	2.3	1.0	-	SCR	INTEGRAL	277V/1PH	3.4	15	54.46, 38.30, 27.24	67.62, 53.48, 44.41	SINGLE MAX SINGLE MIN	A-L					

MODEL NUMBERS SHALL NOT BE CONSIDERED COMPLETE AND MATERIAL SHALL NOT BE ORDERED BY MANUFACTURER AND MODEL NUMBERS ONLY. REVIEW THE COMPLETE DESCRIPTION, NOTES AND SPECIFICATIONS TO DETERMINE THE EXACT MATERIAL AND ACCESSORIES TO BE ORDERED. THE MANUFACTURERS LISTED ARE THE BASIS FOR THE DESIGN.

- NOTES:
- HEATING COIL CAPACITY BASED ON SCHEDULED AIR TEMPERATURE DIFFERENCE (LAT-EAT) AND SCHEDULED MAXIMUM HEATING AIRFLOW.
 - INSTALL FLEXIBLE DUCT CONNECTOR AT INLET CONNECTION.
 - PROVIDE CONTROL POWER (CP) TRANSFORMER BY DIVISION 23. COORDINATE PRIMARY POWER WITH ELECTRICAL DRAWINGS.
 - BOX NOT TO EXCEED SCHEDULED DISCHARGE OR RADIATED SOUND NC LEVEL USING 0.5 INCH PRESSURE DROP.
 - PROVIDE FACTORY INSTALLED, PRESSURE INDEPENDENT, DDC CONTROL PACKAGE.
 - PROVIDE BOX WITH EITHER RIGHT HAND OR LEFT HAND CONFIGURATION AS SHOWN ON DRAWINGS.
 - PROVIDE BOX WITH MAGNETIC CONTACTORS FOR NON-HORIZONTAL MOUNTING.
 - PROVIDE BOX WITH SINGLE POINT ELECTRICAL CONNECTION.
 - INLET SIZE SHOWN IS THE MINIMUM ALLOWABLE INLET SIZE. NO SMALLER SIZES SHALL BE ACCEPTED.
 - PROVIDE HEATER TO MEET OR EXCEED SCHEDULED MBH OUTPUT. NOMINAL INPUT IS BASED ON LISTED MANUFACTURER'S STANDARD PRODUCT. COORDINATE EQUIPMENT POWER SUPPLY WITH ELECTRICAL CONTRACTOR IF DIFFERENT FROM THAT SCHEDULED.
 - VAV BOXES SHALL BE SIZED TO MEET THE SCHEDULED VALUES BASED ON THE FOLLOWING PRIORITIES: 1 - HEATING COIL CAPACITY, 2 - LEAVING AIR TEMPERATURE.

MARK	MANUFACTURER	MODEL	UNIT TYPE	ASSOCIATED OUTDOOR UNIT	COOLING		HEATING		ELECTRICAL	WEIGHT (LBS)	NOTES	
					(°F DB)	(°F WB)	(°F DB)	V/PH				
IU-1	SAMSUNG	AC018B	HIGH WALL	OU-1	74	60	69	208H1	3	15	50	A-J
IU-2	SAMSUNG	AC018B	HIGH WALL	OU-2	74	60	69	208H1	3	15	50	A-J
IU-3	SAMSUNG	AC018B	HIGH WALL	OU-3	74	60	69	208H1	3	15	50	A-J
IU-4	SAMSUNG	AC018B	HIGH WALL	OU-4	74	60	69	208H1	3	15	50	A-J
IU-5	SAMSUNG	AC018B	HIGH WALL	OU-5	74	60	69	208H1	3	15	50	A-J
IU-6	SAMSUNG	AC018B	HIGH WALL	OU-6	74	60	69	208H1	3	15	50	A-J
IU-7	SAMSUNG	AC018B	HIGH WALL	OU-7	74	60	69	208H1	3	15	50	A-J
IU-8	SAMSUNG	AC036B	HIGH WALL	OU-8	74	60	69	208H1	3	15	50	A-J
IU-9	SAMSUNG	AC018B	HIGH WALL	OU-9	74	60	69	208H1	3	15	50	A-J
IU-10	SAMSUNG	AC036B	HIGH WALL	OU-10	74	60	69	208H1	3	15	50	A-J
IU-11	SAMSUNG	AC036B	HIGH WALL	OU-11	74	60	69	208H1	3	15	50	A-J
IU-12	SAMSUNG	AC036B	HIGH WALL	OU-12	74	60	69	208H1	3	15	50	A-J
IU-13	SAMSUNG	AC036B	HIGH WALL	OU-13	74	60	69	208H1	3	15	50	A-J
IU-14	SAMSUNG	AC018B	HIGH WALL	OU-14	74	60	69	208H1	3	15	50	A-J
IU-15	SAMSUNG	AC024B	HIGH WALL	OU-15	74	60	69	208H1	3	15	50	A-J
IU-16	SAMSUNG	AC036B	HIGH WALL	OU-16	74	60	69	208H1	3	15	50	A-J
IU-17	SAMSUNG	AC036B	HIGH WALL	OU-17	74	60	69	208H1	3	15	50	A-J
IU-18	SAMSUNG	AC036B	HIGH WALL	OU-18	74	60	69	208H1	3	15	50	A-J

MODEL NUMBERS SHALL NOT BE CONSIDERED COMPLETE AND MATERIAL SHALL NOT BE ORDERED BY MANUFACTURER AND MODEL NUMBERS ONLY. REVIEW THE COMPLETE DESCRIPTION, NOTES AND SPECIFICATIONS TO DETERMINE THE EXACT MATERIAL AND ACCESSORIES TO BE ORDERED. THE MANUFACTURERS LISTED ARE THE BASIS FOR THE DESIGN.

- NOTES:
- REFER TO MINI SPLIT OUTDOOR UNIT SCHEDULE FOR ADDITIONAL INFORMATION.
 - INDOOR UNIT POWERED THROUGH OUTDOOR UNIT. WIRING BETWEEN INDOOR AND OUTDOOR UNITS PROVIDED BY DIVISION 26 CONTRACTOR. COORDINATE CONDUCTOR QUANTITY WITH MANUFACTURER'S REQUIREMENTS.
 - DISCONNECT SWITCH FOR INDOOR UNIT PROVIDED BY DIVISION 26 CONTRACTOR.
 - COORDINATE SIZE OF CONDUCTOR TERMINATION LUGS WITH CONDUCTOR SIZES SHOWN ON ELECTRICAL DRAWINGS.
 - STARTERS FOR ALL MOTORS SHALL BE PROVIDED INTEGRAL WITH UNIT.
 - CONTRACTOR SHALL VERIFY WITH EQUIPMENT SUPPLIER EXACT ROUTING AND SIZE OF INSULATED REFRIGERANT PIPING. INSTALL PER MANUFACTURER'S RECOMMENDATIONS.
 - PROVIDE WITH FLOAT SWITCH IN PRIMARY DRAIN PAN TO SHUT OFF UNIT WHEN WATER DOES NOT DRAIN PROPERLY.
 - PROVIDE WITH BACNET COMPATIBLE HARD-WIRED WALL-MOUNTED CONTROLLER BY UNIT MANUFACTURER.
 - PROVIDE WITH INTEGRAL CONDENSATE PUMP.

MARK	MANUFACTURER	MODEL	ASSOCIATED INDOOR UNIT	REFR TYPE	COOLING				ELECTRICAL			WEIGHT (LBS)	NOTES	
					AMBIENT (°F DB)	TOTAL (MBH)	SENSIBLE (MBH)	MIN EFFICIENCY (EER)	SEER	V/PH	MCA			MOCP
OU-1	SAMSUNG	AC018B	IU-1	R410A	100	17.6	13.4	12	20	208H1	20.1	25	100	A-K
OU-2	SAMSUNG	AC018B	IU-2	R410A	100	17.6	13.4	12	20	208H1	20.1	25	100	A-K
OU-3	SAMSUNG	AC018B	IU-3	R410A	100	17.6	13.4	12	20	208H1	20.1	25	100	A-K
OU-4	SAMSUNG	AC018B	IU-4	R410A	100	17.6	13.4	12	20	208H1	20.1	25	100	A-K
OU-5	SAMSUNG	AC018B	IU-5	R410A	100	17.6	13.4	12	20	208H1	20.1	25	100	A-K
OU-6	SAMSUNG	AC018B	IU-6	R410A	100	17.6	13.4	12	20	208H1	20.1	25	100	A-K
OU-7	SAMSUNG	AC018B	IU-7	R410A	100	17.6	13.4	12	20	208H1	20.1	25	100	A-K
OU-8	SAMSUNG	AC036B	IU-8	R410A	100	33.1	22.6	9.5	19.2	208H1	24.5	35	160	A-K
OU-9	SAMSUNG	AC018B	IU-9	R410A	100	17.6	13.4	12	20	208H1	20.1	25	100	A-K
OU-10	SAMSUNG	AC036B	IU-10	R410A	100	33.1	22.6	9.5	19.2	208H1	24.5	35	160	A-K
OU-11	SAMSUNG	AC036B	IU-11	R410A	100	33.1	22.6	9.5	19.2	208H1	24.5	35	160	A-K
OU-12	SAMSUNG	AC036B	IU-12	R410A	100	33.1	22.6	9.5	19.2	208H1	24.5	35	160	A-K
OU-13	SAMSUNG	AC036B	IU-13	R410A	100	33.1	22.6	9.5	19.2	208H1	24.5	35	160	A-K
OU-14	SAMSUNG	AC018B	IU-14	R410A	100	17.6	13.4	12	20	208H1	20.1	25	100	A-K
OU-15	SAMSUNG	AC036B	IU-15	R410A	100	22.9	16.4	10	19	208H1	24.1	30	100	A-K
OU-16	SAMSUNG	AC036B	IU-16	R410A	100	33.1	22.6	9.5	19.2	208H1	24.5	35	160	A-K
OU-17	SAMSUNG	AC036B	IU-17	R410A	100	33.1	22.6	9.5	19.2	208H1	24.5	35	160	A-K
OU-18	SAMSUNG	AC036B	IU-18	R410A	100	33.1	22.6	9.5	19.2	208H1	24.5	35	160	A-K

MODEL NUMBERS SHALL NOT BE CONSIDERED COMPLETE AND MATERIAL SHALL NOT BE ORDERED BY MANUFACTURER AND MODEL NUMBERS ONLY. REVIEW THE COMPLETE DESCRIPTION, NOTES AND SPECIFICATIONS TO DETERMINE THE EXACT MATERIAL AND ACCESSORIES TO BE ORDERED. THE MANUFACTURERS LISTED ARE THE BASIS FOR THE DESIGN.

- NOTES:
- REFER TO MINI SPLIT INDOOR UNIT SCHEDULE FOR ADDITIONAL INFORMATION.
 - INDOOR UNIT POWERED THROUGH OUTDOOR UNIT. WIRING BETWEEN INDOOR AND OUTDOOR UNITS PROVIDED BY DIVISION 26 CONTRACTOR. COORDINATE CONDUCTOR QUANTITY WITH MANUFACTURER'S REQUIREMENTS.
 - EQUIPMENT CAPACITY SCHEDULED IS MINIMUM CAPACITY THAT MUST BE PROVIDED AT AMBIENT TEMPERATURE INDICATED.
 - CONTRACTOR SHALL VERIFY WITH EQUIPMENT SUPPLIER EXACT ROUTING AND SIZE OF INSULATED REFRIGERANT PIPING. INSTALL PER MANUFACTURER'S RECOMMENDATIONS.
 - DISCONNECT SWITCH PROVIDED BY DIVISION 26 CONTRACTOR.
 - COORDINATE SIZE OF CONDUCTOR TERMINATION LUGS WITH CONDUCTOR SIZES SHOWN ON ELECTRICAL DRAWINGS.
 - STARTERS FOR ALL MOTORS SHALL BE PROVIDED INTEGRAL WITH UNIT.
 - PROVIDE CONDENSER COIL HAIL GUARDS.
 - PROVIDE PRE-ENGINEERED ROOF EQUIPMENT SUPPORTS WITH MINIMUM HEIGHT REQUIRED TO MAINTAIN BOTTOM OF EQUIPMENT A MINIMUM OF 16 INCHES ABOVE FINISHED ROOF SURFACE. COORDINATE WITH ROOF INSULATION THICKNESS.
 - PROVIDE LOW AMBIENT KIT FOR COOLING OPERATION DOWN TO 0°F.

MARK	SERVICE	MANUFACTURER	MODEL	CFM	MAX THROAT VEL. (FPM)	MAX PD. (IN)	THROAT (L" x W")	CURB (L" x W")
IH 1	INTAKE	GREENHECK	FGI	200	200	0.01	12x12	12x12

MODEL NUMBERS SHALL NOT BE CONSIDERED COMPLETE AND MATERIAL SHALL NOT BE ORDERED BY MANUFACTURER AND MODEL NUMBERS ONLY. REVIEW THE COMPLETE DESCRIPTION, NOTES AND SPECIFICATIONS TO DETERMINE THE EXACT MATERIAL AND ACCESSORIES TO BE ORDERED. THE MANUFACTURER LISTED IS THE BASIS OF DESIGN.

- NOTES:
- PROVIDE WITH INTEGRAL BIRDSCREEN MOTORIZED DAMPER.
 - PROVIDE 13-1/2" TALL INSULATED ROOF CURB WITH DAMPER TRAY.

MARK	SERVED FROM	ZONE SERVED	MANUFACTURER	MODEL	INLET SIZE (IN)	PRIMARY (CFM)	MIN PRIM (CFM)	CP TRANS V/PH	SOUND POWER		CONTROL TYPE	NOTES
									RADIATED	DISCHARGE		
VAV	RTU-1	Security Electronics	PRICE	SDV	7	515	0	BY DIV 23	57, 49, 41, 34, 28, 25	72, 65, 55, 51, 47, 44	SINGLE MAXIMUM	A-H

MODEL NUMBERS SHALL NOT BE CONSIDERED COMPLETE AND MATERIAL SHALL NOT BE ORDERED BY MANUFACTURER AND MODEL NUMBERS ONLY. REVIEW THE COMPLETE DESCRIPTION, NOTES AND SPECIFICATIONS TO DETERMINE THE EXACT MATERIAL AND ACCESSORIES TO BE ORDERED. THE MANUFACTURERS LISTED ARE THE BASIS FOR THE DESIGN.

MARK	MANUFACTURER	SERVICE	MODEL	CONSTRUCTION TYPE	FACE TYPE	MOUNTING LOCATION	BORDER TYPE	FACE SIZE (IN)	MAX NC	MAX PRESS DROP (IN W.C.)	NOTES
CSD2	PRICE	SUPPLY	SFD	ALUMINUM	PLAQUE	CEILING	3	12x12	25	0.1	A-G
CRG1	PRICE	SUPPLY	MSBP	ALUMINUM	PERFORATED	CEILING	3	SEE PLANS	25	0.1	B-F
CRG2	PRICE	RETURN	80	ALUMINUM	EGGCRATE	CEILING	3	24x24	25	0.1	B-F
CRG3	PRICE	RETURN	80	ALUMINUM	EGGCRATE	CEILING	3	12x12	25	0.1	B-F
CEG1	PRICE	EXHAUST	80	ALUMINUM	EGGCRATE	CEILING	3	24x24	25	0.1	B-F
CEG2	PRICE	EXHAUST	80	ALUMINUM	EGGCRATE	CEILING	3	12x12	25	0.1	B-F
CEG3	PRICE	EXHAUST	MSBP	ALUMINUM	PERFORATED	CEILING	3	SEE PLANS	25	0.1	B-F
WEG1	PRICE										

MECHANICAL SYMBOLS (v2.12)		NOTE: THIS IS A MASTER LEGEND AND NOT ALL SYMBOLS, ABBREVIATIONS, ETC. ARE NECESSARILY USED ON THE DRAWINGS.	
CONTROLS SYMBOLS AND NOMENCLATURE			
	FLUE DAMPER (BOILERS)		HOT GAS REHEAT COIL
	BOILER		COOLING COIL
	COOLING TOWER		FURNACE
	CONDENSING UNIT		HEATING COIL
	FLUID COOLER		DAMPER - GENERIC BLADE TYPE
	WATER-COOLED CHILLER		DAMPER - OPPOSED BLADE TYPE
	AIR-COOLED CHILLER		DAMPER - PARALLEL BLADE TYPE
	GENERIC HEAT EXCHANGER		FLEXIBLE SENSING ELEMENT
	SHELL AND TUBE HEAT EXCHANGER		AIRFLOW STATION
	BASIN HEATER		PUMP
	GROUND HEAT EXCHANGER		FAN
	HEAT RECOVERY WHEEL		HUMIDIFIER
	AIR BYPASS DAMPER		AIR FILTER
	AIRFLOW MEASURING STATION		3-WAY CONTROL VALVE
	DIRECT EXPANSION COOLING UNIT CONTROLLER		2-WAY CONTROL VALVE
	FURNACE BURNER CONTROLLER		AIR BYPASS DAMPER
	SILICON-CONTROLLED RECTIFIER		AIRFLOW MEASURING STATION
	ELECTRIC HEATER CONTROL (MODULATING)		DIRECT EXPANSION COOLING UNIT CONTROLLER
	ELECTRIC HEATER CONTROLLER (ON/OFF)		FURNACE BURNER CONTROLLER
	ELECTRONIC COMMUTATED MOTOR		SILICON-CONTROLLED RECTIFIER
	VARIABLE FREQUENCY DRIVE		ELECTRIC HEATER CONTROL (MODULATING)
	MOTOR STARTER		ELECTRIC HEATER CONTROLLER (ON/OFF)
	LOW LIMIT TEMPERATURE CONTROLLER (FREEZE/STAT)		ELECTRONIC COMMUTATED MOTOR
	EMERGENCY PUSH BUTTON		VARIABLE FREQUENCY DRIVE
			MOTOR STARTER
			LOW LIMIT TEMPERATURE CONTROLLER (FREEZE/STAT)
			EMERGENCY PUSH BUTTON

	RISER DESIGNATION		MOTORIZED DAMPER
	FIRE DAMPER		BACKDRAFT DAMPER
	FIRE SMOKE DAMPER		VOLUME DAMPER
	SMOKE DAMPER		HUMIDISTAT
	SMOKE DETECTOR		THERMOSTAT
	SD (SD-SUPPLY / RD-RETURN)		THERMOSTAT
	BTU METER		PRESSURE SENSOR
	CARBON MONOXIDE SENSOR		POLLUTANT ALARM
	CARBON DIOXIDE SENSOR		PULL STATION
	CONTROL PANEL		RELAY
	CURRENT CIRCUIT RELAY		REFRIGERANT LEAK SENSOR
	DIFFERENTIAL PRESSURE SENSOR		SENSOR - GENERIC
	ELECTRIC METER		STATIC PRESSURE PORT
	FLOW METER; FUEL METER		SWITCH
	FLOW SWITCH		TEMPERATURE SENSOR
	HUMIDITY SENSOR		WATER METER
POINT TYPE			
AI	ANALOG INPUT (MODULATING)		
AO	ANALOG OUTPUT (MODULATING)		
AV	ANALOG VALUE (VIRTUAL)		
BI	BINARY INPUT (ON/OFF, OPEN/CLOSED, ETC)		
BO	BINARY OUTPUT (ON/OFF, OPEN/CLOSED, ETC)		
BV	BINARY VALUE (VIRTUAL)		
COM	COMMUNICATION LINK		
MI	MULTI-STATE INPUT		
MO	MULTI-STATE OUTPUT		
MV	MULTI-STATE VALUE (VIRTUAL)		
ABBREVIATIONS			
X	GENERIC INDICATOR OF PLAN MARK NUMBER OR QTY		
=>	NOT EQUAL TO		
BAS	BUILDING AUTOMATION SYSTEM		
CHWS	CHILLED WATER SUPPLY		
CHWR	CHILLED WATER RETURN		
CMD	COMMAND		
CP	CONTROL PANEL		
CV	CONTROL VALVE		
CWS	CONDENSER WATER SUPPLY		
CWR	CONDENSER WATER RETURN		
DCW	DOMESTIC COLD WATER		
DDC	DIRECT DIGITAL CONTROL		
EDC	ELECTRICAL CONTRACTOR		
EOA	ECONOMIZER OUTSIDE AIR		
EQ	EQUALIZER		
EM	EQUIPMENT MANUFACTURER		
FA/C	FIRE ALARM CONTRACTOR		
FIP	FAIL IN POSITION		
G	NATURAL GAS		
HWS	HEATING WATER SUPPLY		
HWR	HEATING WATER RETURN		
HPWS	HEAT PUMP WATER SUPPLY		
HPWR	HEAT PUMP WATER RETURN		
LPS	LOW PRESSURE STEAM SUPPLY		
LPC	LOW PRESSURE STEAM CONDENSATE		
M/C	MECHANICAL CONTRACTOR		
MIN	MINIMUM, MINUTES		
MOA	MINIMUM OUTSIDE AIR		
NC	NORMALLY CLOSED		
NIA	NOT IN AUTO (IN HAND)		
NO	NORMALLY OPEN		
PID	PROPORTIONAL INTEGRAL DERIVATIVE		
RA	RETURN AIR		
REA	RELIEF/EXHAUST AIR		
SA	SUPPLY AIR		
SCHED	AS SCHEDULED ON DRAWINGS		
SPEC	SPECIFIED		
SPT	SETPOINT		
TBD	TO BE DETERMINED		
T/C/C	TEMPERATURE CONTROLS CONTRACTOR		
WIRING TYPES			
---	POWER WIRING		
- - -	SYSTEM CONTROL WIRING		
- . -	BUILDING AUTOMATION WIRING		

PROJECT DESIGN CONDITIONS																									
CLIMATE CONDITIONS			WEATHER STATION			REFERENCE			BUILDING OPERATING HOURS:																
WEATHER STATION: EDGAR COUNTY AP			EDGAR COUNTY AP			2021 ASHRAE			MONDAY - FRIDAY 24/7																
CLIMATE ZONE: 4A			4A			2021 ASHRAE			SATURDAY 24/7																
ASHRAE HEATING: 99.6%			0.5 °F DB						SUNDAY 24/7																
DESIGN HEATING CONDITIONS:			0.5 °F DB						HOLIDAY 24/7																
HUMIDIFICATION: 99.6%			-5.6 °F DB			4.2 gr/lb 2.1 °F DB																			
ASHRAE COOLING: 0.4%			91.1 °F DB			75.0 °F WB																			
DESIGN COOLING CONDITIONS:			93 °F DB			75 °F WB																			
DEHUMIDIFICATION: 0.4%			77.4 °F DB			146.0 gr/lb 84.9 °F DB																			
SPACE / UNIT DESCRIPTION		COOLING / DEHUMIDIFICATION				HEATING		HUMIDIFICATION		ZONE VENTILATION RESET		SPACE OPERATING HOURS OCCUPIED / UNOCCUPIED		NOTES											
		OCC °F		UNOCC °F		OCC °F		UNOCC °F		CONTROL METHOD		BASE PPM		MAXIMUM PPM		DAYS OF THE WEEK									
ADMINISTRATIVE SPACES		74		80		50%		NA		69		60		NA		NA		M-F 24/7		SAT 24/7		SUN 24/7		B-D	
DAYROOMS/USUAL SPACES		74		80		50%		NA		69		60		NA		NA		24/7		24/7		24/7		B-D	

NOTES:
 B. ZONE LEVEL SET POINT CONDITIONS SHALL BE AS SCHEDULED UNLESS OTHERWISE SCHEDULED OR NOTED ON THE DRAWINGS FOR ROOM SPECIFIC SPACE CONDITIONS.
 C. ZONE LEVEL OCCUPANCY HOUR SCHEDULE SHALL BE PER BUILDING OPERATING HOURS UNLESS OTHERWISE SCHEDULED.
 D. ZONE LEVEL CONTROLS SHALL BE CAPABLE OF OPERATING WITH INDEPENDENT OCCUPANCY SCHEDULES.

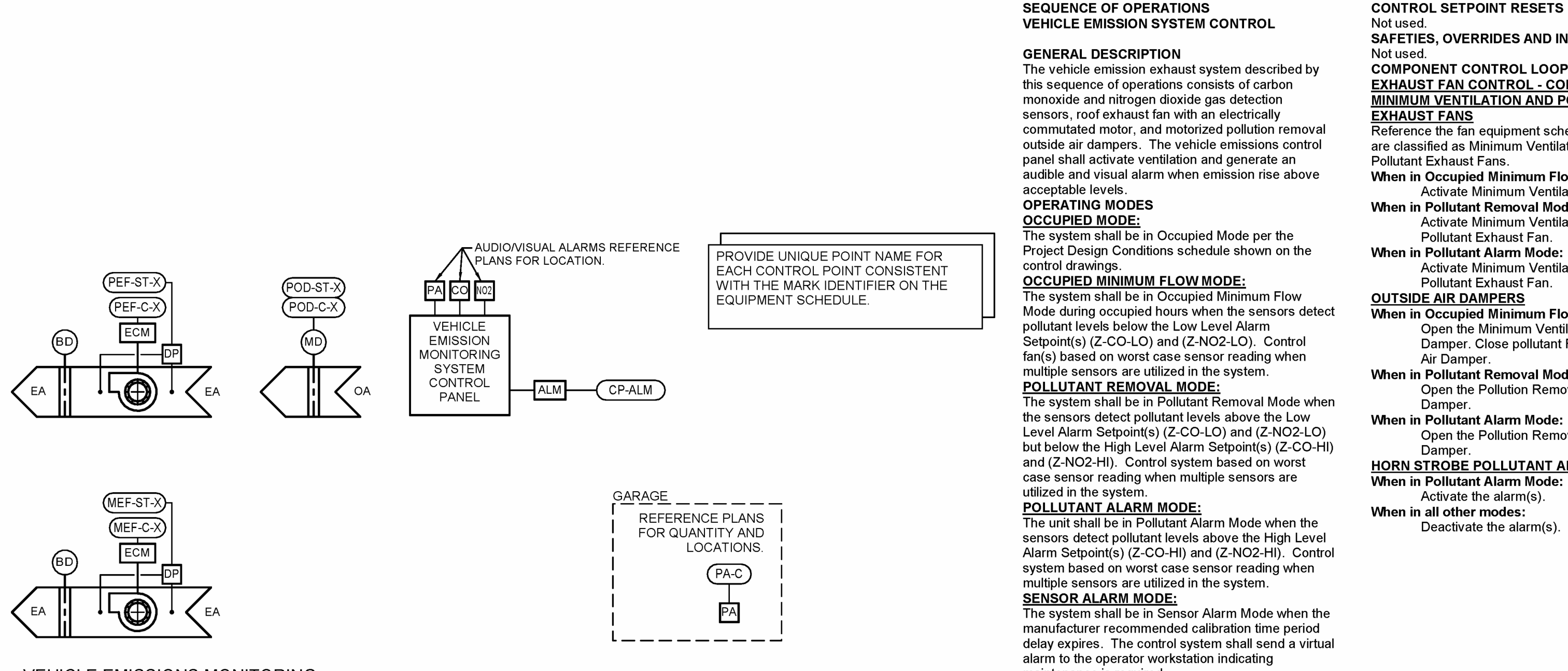

POINTS LIST - VEHICLE EMISSION EXHAUST SYSTEM											
POINT ID	DESCRIPTION	POINT TYPE	SETPOINT	FAIL POSITION	TRENDING STORAGE	DISPLAY GRAPHIC	ALARM STATUS	ALARM RANGE	NOTES		
MINIMUM VENTILATION EXHAUST FAN											
MEF-C-X	MINIMUM VENTILATION EXHAUST FAN COMMAND (START/STOP)	BV				X	X		G		
MEF-ST-X	MINIMUM VENTILATION EXHAUST FAN STATUS	BI					X	EF-ST <=> EF-C	G		
POLLUTION EXHAUST FAN											
PEF-C-X	POLLUTION EXHAUST FAN COMMAND (START/STOP)	BV				X	X		G		
PEF-ST-X	POLLUTION EXHAUST FAN STATUS	BI					X	EF-ST <=> EF-C	G		
POLLUTION REMOVAL OUTSIDE AIR DAMPER (2-POSITION)											
POD-C-X	POLLUTION REMOVAL OUTSIDE AIR DAMPER COMMAND	BO		NO		X	X		G		
POD-ST-X	POLLUTION REMOVAL OUTSIDE AIR DAMPER STATUS	BI			X	X	X	OD-ST <=> OD-C	G		
VEHICLE EXHAUST ALARMS											
CP-ALM	CONTROL PANEL FAILURE	BI					X	ON ACTIVATION	H.1		
Z-CO-LO	ZONE CARBON MONOXIDE LOW LEVEL	BV	25 PPM				X	Z-CO > Z-CO-LO			
Z-CO-HI	ZONE CARBON MONOXIDE HIGH LEVEL	BV	200 PPM				X	Z-CO > Z-CO-HI			
Z-NO2-LO	ZONE NITROGEN DIOXIDE LOW LEVEL	BV	1 PPM				X	Z-NO2 > Z-NO2-LO			
Z-NO2-HI	ZONE NITROGEN DIOXIDE HIGH LEVEL	BV	3 PPM				X	Z-NO2 > Z-NO2-HI			
PA-C	POLLUTANT ALARM COMMAND	BI			X	X	X	SEE SEQUENCE			
SNR-ALM	SENSOR MAINTENANCE ALARM	BV					X	SEE SEQUENCE			

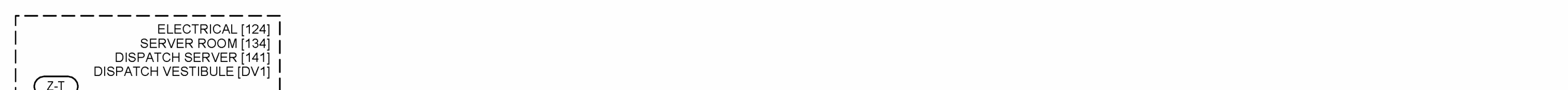

POINTS LIST - SPACE TEMPERATURE MONITORING							
POINT ID	DESCRIPTION	POINT TYPE	UNITS	GRAPHIC DISPLAY	STATUS ALARM	ALARM RANGE	NOTES
Z-T	ZONE TEMPERATURE	AI	°F	X	X	Z-T > 78	D

NOTES:
 D. POINT SHALL BE ADJUSTABLE

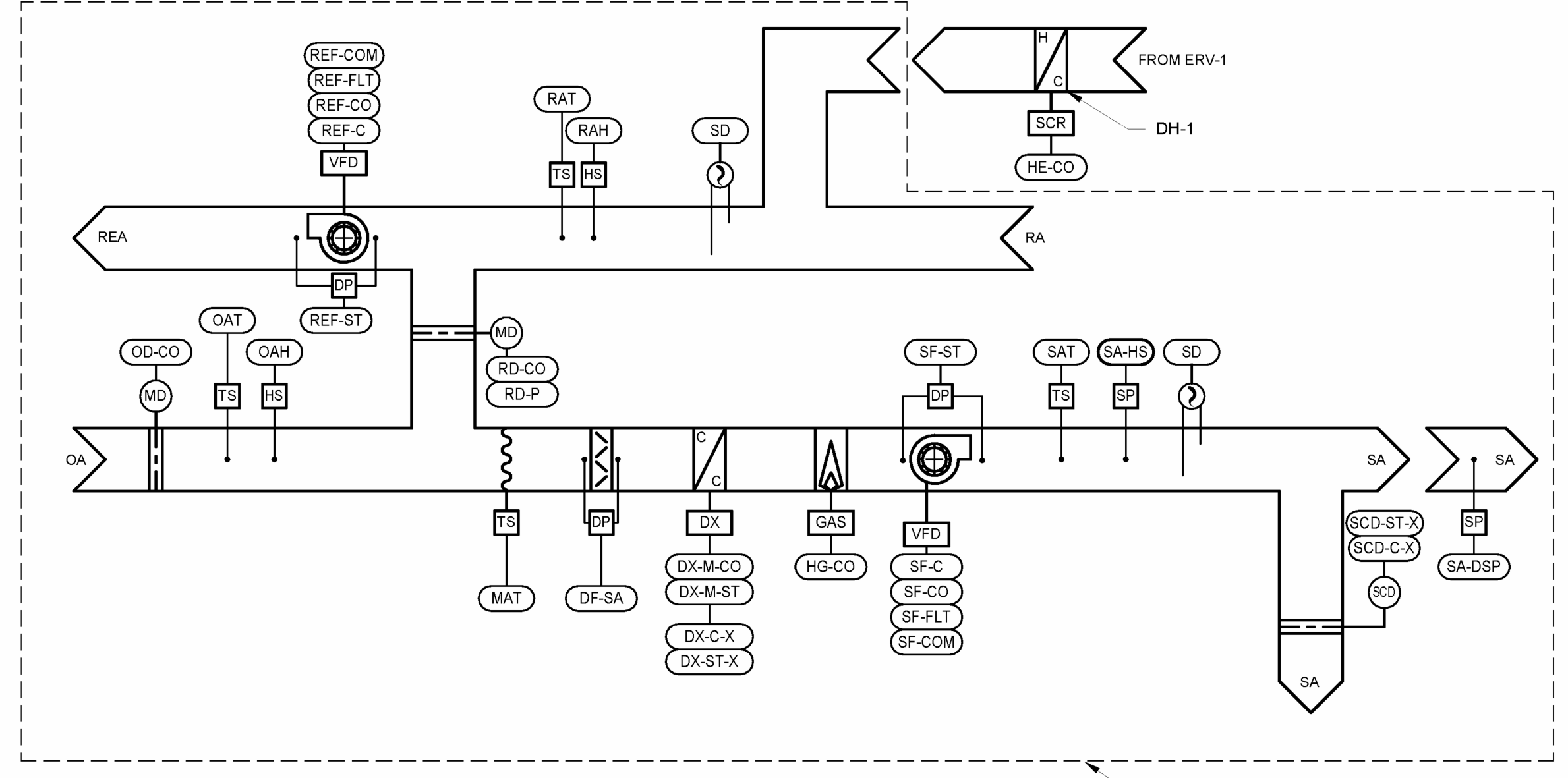

1 RTU-1 & DH-1 CONTROL DIAGRAM NTS

POINTS LIST - MULTIZONE VARIABLE AIR VOLUME AHU (MZVAV AHU)

POINT ID	DESCRIPTION	POINT TYPE	DEFAULT SETPOINT	FAIL POSITION	TRENDING STORAGE	GRAPHIC DISPLAY	STATUS ALARM	ALARM RANGE	NOTES
GLOBAL VALUES									
BDP	BUILDING DIFFERENTIAL PRESSURE	AI			X	X			K
BDP-SP	BUILDING DIFFERENTIAL PRESSURE SETPOINT	AV	0.05 INWG		X				D,E
USD	AIR HANDLING UNIT - UNIT START DELAY	AV	20 MIN						D
MS-DLY	MODE SWITCH DELAY	AV	2 MIN						D
ASSOCIATED ZONE TERMINAL VALUES (TYPICAL FOR EACH ZONE SERVED BY SYSTEM)									
X-Z-T	"X" ZONE TEMPERATURE	AV							F,Q
X-Z-T-R	"X" ZONE HEAT/COOL REQUEST	AV							F,Q
X-Z-T-W	"X" ZONE HEAT/COOL REQUEST WEIGHTING FACTOR	AV	1						D,F,P,Q
AIR SENSING									
SAT	SUPPLY AIR TEMPERATURE	AI			X	X	X	SAT < 48 F OR SAT > 100 F	D
SAT-SP	SUPPLY AIR TEMPERATURE SETPOINT	AV	52 F		X	X			C,D
SAT-DB	SUPPLY AIR TEMPERATURE DEADBAND	AV	5 F		X	X			C,D
SA-HS	SUPPLY DUCT HIGH STATIC CONTROLLER	BI	3.0 INWG		X		X	ON ACTIVATION	E
RAT	RETURN AIR TEMPERATURE	AI			X	X			
RAH	RETURN AIR RELATIVE HUMIDITY	AI			X	X			
RAT-SP	RETURN AIR TEMPERATURE SETPOINT	AV	55 F		X	X			C,D
OAT	OUTSIDE AIR TEMPERATURE	AI			X	X			
OAH	OUTSIDE AIR RELATIVE HUMIDITY	AI			X	X			
OAE	OUTSIDE AIR ENTHALPY	AV			X	X			
MAT	MIXED AIR TEMPERATURE	AI			X	X			I
AIRFLOW SENSING AND CONTROL									
SA-DSP	SUPPLY AIR DUCT STATIC PRESSURE	AI			X	X			
SA-DSP-SP	SUPPLY AIR DUCT STATIC PRESSURE SETPOINT	AV							
ECONOMIZER MODE - FIXED ENTHALPY WITH FIXED DRY-BULB TEMPERATURE ENABLED									
OAT-HL	ECONOMIZER OUTDOOR AIR DRY BULB HIGH LIMIT	AV	75 F		X				D
OAE-HL	ECONOMIZER OUTSIDE AIR ENTHALPY HIGH LIMIT	AV	28 BTU/LB		X				D
FAN PRESSURE RESET TRIM AND RESPOND LOGIC									
DSP-0	DUCT STATIC PRESSURE DEFAULT SETPOINT	AV	SCHED		X				D,E,O
DSP-MIN	DUCT STATIC PRESSURE MINIMUM SETPOINT	AV	0.25 INWG		X				D,E,O
DSP-MAX	DUCT STATIC PRESSURE MAXIMUM SETPOINT	AV	1.2 INWG		X		X	DSP > DSP-MAX	D,E,O
TR-TD	TRIM AND RESPOND TIME DELAY	AV	10 MIN						D
TR-T	TRIM AND RESPOND TIME STEP	AV	2 MIN						D
TR-R	CURRENT NUMBER OF REQUESTS	AV							
TR-I	NUMBER OF IGNORED REQUESTS	AV	1		X				D
TR-TRIM	TRIM AMOUNT	AV	-0.04 INWG						D
TR-RES	RESPOND AMOUNT	AV	0.03 INWG						D
TR-RES-MAX	MAXIMUM RESPOND AMOUNT	AV	0.12 INWG						D
SUPPLY AIR TEMPERATURE RESET - DIRECT OUTSIDE AIR RESET									
OAT-RST-MIN	OUTSIDE AIR TEMP RESET MINIMUM VALUE	AV	60F						D
OAT-RST-MAX	OUTSIDE AIR TEMP RESET MAXIMUM VALUE	AV	70F						D
SAT-MIN	SUPPLY AIR TEMPERATURE MINIMUM SETPOINT	AV	52 F		X	X			D
SAT-MAX	SUPPLY AIR TEMPERATURE MAXIMUM SETPOINT	AV	70 F		X	X			D
SMOKE DETECTOR INTERLOCK									
SD	SMOKE DETECTOR STATUS	BI					X	X	ON ACTIVATION
SUPPLY FAN									
SF-COM	SUPPLY FAN VFD COMMUNICATION	COM				X			
SF-C	SUPPLY FAN COMMAND (ENABLE/DISABLE)	BO			X	X			
SF-CO	SUPPLY FAN CONTROL OUTPUT - SPEED (PERCENT)	AV			X	X			
SF-CO-MIN	SUPPLY FAN MINIMUM SPEED SETPOINT	AV	() HZ		X				D,E
SF-CO-MAX	SUPPLY FAN MAXIMUM SPEED SETPOINT	AV	() HZ		X				D,E
SF-ST	SUPPLY FAN STATUS	BI			X	X	X	SF-ST ↔ SF-C	
SF-FLT	SUPPLY FAN VFD FAULT	BV			X	X	X	COMMON ALARM	
SF-RUN	SUPPLY FAN RUN TIME	AV			X	X			
SF-NIA	SUPPLY FAN NOT IN AUTO (IN HAND)	BV				X	X	NOTIFY AT FRONT END	
SF-R	SUPPLY FAN REQUEST TOTAL	AV							
SF-I	SUPPLY FAN NUMBER OF IGNORED REQUESTS	AV	1		X				D
RELIEF-EXHAUST FAN									
REF-COM	RELIEF-EXHAUST FAN VFD COMMUNICATION	COM				X			
REF-C	RELIEF-EXHAUST FAN COMMAND (ENABLE/DISABLE)	BO			X	X			
REF-CO	RELIEF-EXHAUST FAN CONTROL OUTPUT - SPEED (PERCENT)	AV			X	X			
REF-CO-MIN	RELIEF-EXHAUST FAN MINIMUM SPEED SETPOINT	AV	() HZ		X				D,E
REF-CO-MAX	RELIEF-EXHAUST FAN MAXIMUM SPEED SETPOINT	AV	() HZ		X				D,E
REF-ST	RELIEF-EXHAUST FAN STATUS	BI			X	X	X	REF-ST ↔ REF-C	
REF-FLT	RELIEF-EXHAUST FAN VFD FAULT	BV			X	X	X	COMMON ALARM	
REF-RUN	RELIEF-EXHAUST FAN RUN TIME	AV			X	X			
REF-NIA	RELIEF-EXHAUST FAN NOT IN AUTO (IN HAND)	BV			X	X	X	NOTIFY AT FRONT END	
PC-DLY	PRESSURE CONTROL DELAY	AV	3 MIN		X				D,E
OUTSIDE AIR DAMPER									
OD-CO	OUTSIDE AIR DAMPER CONTROL OUTPUT	AO		NC	X	X			
SUPPLY AIR DIRTY FILTER INDICATION									
DF-SA	SUPPLY AIR FILTER PRESSURE DIFFERENTIAL	AI			X	X			
DF-SA-SP	SUPPLY AIR FILTER PRESSURE DIFFERENTIAL SETPOINT	AV	SCHED				X	ON ACTIVATION	D
COOLING COIL - DX MODULATING AND BINARY STAGES									
DX-M-CO	DX MODULATING COMPRESSOR CONTROL OUTPUT	AO			X	X			
DX-M-ST	DX MODULATING COMPRESSOR STATUS	AI			X	X	X	DX-M-ST ↔ DX-M-CO	
DX-M-RUN	DX MODULATING COMPRESSOR RUNTIME	AV			X	X			
DX-C-X	DX COMPRESSOR STAGE "X" COMMAND	BO			X	X			G
DX-ST-X	DX COMPRESSOR STAGE "X" STATUS	BI			X	X	X	DX-ST-X ↔ DX-C-X	G
DX-RUN-X	DX COMPRESSOR STAGE "X" RUNTIME	AV			X	X			G
DEHUMIDIFICATION									
RAH-SP	RETURN AIR RELATIVE HUMIDITY SETPOINT	AV	50% RH		X				D
RAH-DB	RETURN AIR RELATIVE HUMIDITY DEADBAND	AV	5% RH		X				D
HEATING COIL - GAS FURNACE MODULATING									
HG-CO	GAS FURNACE HEAT MODULATION CONTROL OUTPUT	AO			X	X			

ALL POINTS SHOWN SHALL BE PROVIDED BY BAS CONTRACTOR UNLESS NOTED OTHERWISE.
PROVIDE UNIQUE POINT NAME FOR EACH CONTROL POINT CONSISTENT WITH THE MARK IDENTIFIER ON THE EQUIPMENT SCHEDULE (E.G. RH01-D-C).
REFER TO SPECIFICATION FOR ADDITIONAL REQUIREMENTS.

NOTES:
C. REFERENCE PROJECT DESIGN CONDITIONS SCHEDULE OR EQUIPMENT SCHEDULE FOR SETPOINT AS APPROPRIATE.
D. POINT SHALL BE ADJUSTABLE.
E. DETERMINE SETPOINT DURING TESTING AND BALANCING. COORDINATE WITH THE TEST AND BALANCE CONTRACTOR.
F. POINT IS ASSOCIATED WITH ANOTHER SYSTEM AND INTEGRATED THROUGH THE BAS SYSTEM FOR USE IN THIS SEQUENCE.
G. COORDINATE NUMBER OF STAGES FOR CONTROL WITH EQUIPMENT FURNISHED.
H. DEVICE AND RELAY FROM FIRE ALARM SYSTEM PROVIDED BY DIVISION 28. DISPLAY DETECTOR RELAY STATUS (NORMAL/ALARM) AT BAS FRONT END.
K. ZONE STATIC PRESSURE SHALL BE TIME-AVERAGED WITH A SLIDING 5-MINUTE WINDOW AND 15 SECOND SAMPLING RATE (TO DAMPEN FLUCTUATIONS). THE AVERAGED VALUE SHALL BE DISPLAYED AND USED FOR CONTROL.
O. VALUES IN SETPOINT COLUMN ARE DEFAULT SETPOINTS. VALUE SHALL BE CHANGED BASED ON PERFORMANCE INFORMATION IN THE EQUIPMENT SCHEDULE AND SUBSEQUENTLY TUNED DURING EQUIPMENT STARTUP.
P. VALUE SHALL BE INDEPENDENTLY ADJUSTABLE FOR EACH INDIVIDUAL AIR TERMINAL UNIT.
Q. SUBSTITUTE "X" FOR THE EQUIPMENT TAG OF ASSOCIATED TERMINAL UNIT (E.G. "VAV-2-1"). DO THIS FOR EACH TERMINAL UNIT ASSOCIATED WITH AHU.

SEQUENCE OF OPERATIONS EF-1

GENERAL DESCRIPTION
The units described by this sequence consist of an exhaust fan with an electronically commutated (EC) motor.

OPERATING MODES

OCCUPIED MODE:
The fan shall be in occupied mode during occupied hours per the project design conditions schedule shown on the control drawings

CONTROL SETPOINT RESETS

Not Used.

SAFETIES, OVERRIDES AND INTERLOCKS

Not Used.

COMPONENT CONTROL LOOPS

FAN CONTROL - CONSTANT VOLUME BAS SCHEDULED
When in Occupied Mode:
Use the ECM motor for soft start and to balance the fan for constant speed operation at the scheduled airflow value.

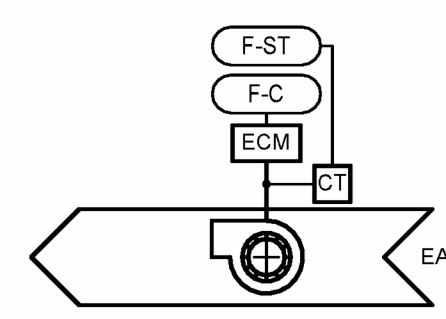

EF-2, EF-3, EF-4 CONTROL DIAGRAM NTS

POINTS LIST - EXHAUST FAN

POINT ID	DESCRIPTION	POINT TYPE	SETPOINT	FAIL POSITION	TRENDING STORAGE	GRAPHIC DISPLAY	STATUS ALARM	ALARM RANGE	NOTES
FAN									
F-C	FAN COMMAND (START/STOP)	BO							
F-ST	FAN STATUS	BI							F-ST ↔ F-C

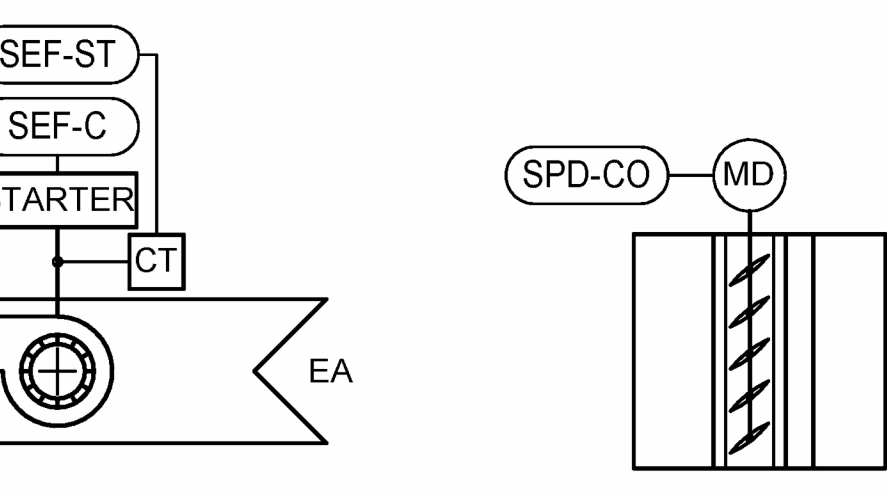

SEF-7 CONTROL DIAGRAM NTS

PROVIDE ONE DP SENSOR FOR EACH SMOKE CONTROL ZONE FOR THE SYSTEM.

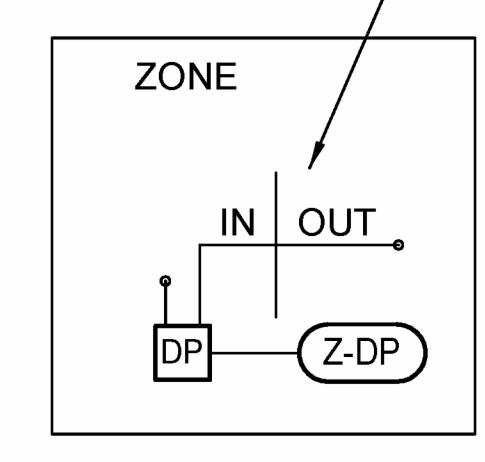

QUANTITY OF SMOKE EXHAUST FANS AND SMOKE PRESSURIZATION DAMPERS DIFFERS BETWEEN SYSTEMS. REFERENCE DRAWINGS FOR QUANTITY OF FANS AND DAMPERS FOR EACH SYSTEM.

SMOKE EXHAUST FAN

Smoke control mode shall be initiated for the smoke exhaust fan when any exhaust air smoke detector in the space the exhaust fan serves senses smoke.

When in Smoke Control Mode:
The fan shall be ON.

When in all other modes:
The fan shall be OFF.

SMOKE CONTROL DAMPERS

Smoke control mode shall be initiated for the smoke control dampers when any exhaust air smoke detector in the space the dampers serve senses smoke.

When in Smoke Control Mode:
The dampers shall be CLOSED.

When in all other modes:
The dampers shall be OPEN.

SMOKE PRESSURIZATION DAMPER

Smoke control mode shall be initiated for the smoke pressurization damper when any exhaust air smoke detector in the space the damper serves senses smoke.

When in Smoke Control Mode:
The damper shall modulate to maintain a negative 0.05" W.G. pressure differential between the space and the adjacent hallway.

When in all other modes:
The damper shall be CLOSED.

POINTS LIST - SMOKE CONTROL FANS (SEF-7)

POINT ID	DESCRIPTION	POINT TYPE	DEFAULT SET POINT	FAIL POSITION	TRENDING INTERVAL	TRENDING STORAGE	DISPLAY GRAPHIC	STATUS ALARM	ALARM RANGE	NOTES
Z-DP	ZONE DIFFERENTIAL PRESSURE	AI				X	X			K
Z-DP-SP	ZONE DIFFERENTIAL PRESSURE SETPOINT	AI	0.05 INWG			X				D,E
SEF-C	SMOKE EXHAUST FAN COMMAND (START/STOP)	BO				X	X			
SEF-ST	SMOKE EXHAUST FAN STATUS	BI						X		RF-ST ↔ RF-C
SPD-CO	SMOKE PRESSURIZATION DAMPER CONTROL OUTPUT	AO		NC			X			
SMD-ST-X	SMOKE ZONE CONTROL DAMPER COMMAND	BO		NC			X			DOA-ST ↔ DOA-C
SMD-ST-X	SMOKE ZONE CONTROL DAMPER STATUS	BI					X			

ALL POINTS SHOWN SHALL BE PROVIDED BY BAS CONTRACTOR UNLESS NOTED OTHERWISE.
D. POINT SHALL BE ADJUSTABLE.
E. DETERMINE SETPOINT DURING TESTING AND BALANCING. COORDINATE WITH THE TEST AND BALANCE CONTRACTOR.
K. STATIC PRESSURE SHALL TIME-AVERAGED WITH A SLIDING 5-MINUTE WINDOW AND 15 SECOND SAMPLING RATE (TO DAMPEN FLUCTUATIONS). THE AVERAGED VALUE SHALL BE DISPLAYED AND USED FOR CONTROL.

MIXED AIR DAMPERS - DAMPER POSITION TRACKING CONTROL

The mixed air damper assembly consists of an Outside Air Damper (OD) and Return Air Damper (RD) damper that modulate with an inversely proportional relationship. The controller shall use linear interpolation to define Outside Air Damper and RD positions that ensure the desired Outside Airflow Setpoint (OA-AF-SP) is provided as the supply air fan speed changes. During startup, correlate Outside Air Damper and RD positions that yield the Outside Airflow Setpoint (OA-AF-SP) according to the following table:

Supply Fan Speed	OD Position	RD Position
SF-CO-MIN	OD-P1	RD-P1
SF-CO-MAX	OD-P2	RD-P2

Calculation of the Outside Air Damper Position Setpoint (OD-P-SP) based on the current Outside Airflow Setpoint (OA-AF-SP) and linear interpolation as follows:
At least once per minute while the zone is in Occupied mode, calculate Outside Air Damper Position Setpoint (OD-P-SP) as a linear interpolation between OD-P1 and OD-P2 based on the current fan speed.

Calculation of the Return Air Damper Position Setpoint (RD-P-SP) based on the current Outside Airflow Setpoint (OA-AF-SP) using similar logic presented above.

When in Occupied Mode:
When in Economizer Mode:
Modulate the Outside Air Damper and Return Air Damper to maintain the Supply Air Temperature (SAT) at the Supply Air Temperature Setpoint (SAT-SP).

Outside Air Damper is permitted to modulate between the fully open position and the calculated Outside Air Damper Position Setpoint (OD-P-SP).
RD is permitted to modulate between the closed position and the calculated Return Air Damper Position Setpoint (RD-P-SP).
When not in Economizer Mode:
Modulate the Outside Air Damper to its calculated Outside Air Damper Position Setpoint (OD-P-SP) based on the Outside Airflow Setpoint (OA-AF-SP).

Modulate the Return Air Damper to its calculated Return Air Damper Position Setpoint (RD-P-SP) based on the Outside Airflow Setpoint (OA-AF-SP).
RD is permitted to modulate between the closed position and the calculated Return Air Damper Position Setpoint (RD-P-SP).
When not in Economizer Mode:
Modulate the Outside Air Damper to its calculated Outside Air Damper Position Setpoint (OD-P-SP) based on the Outside Airflow Setpoint (OA-AF-SP).

SUPPLY AIR FILTER MONITORING - DIFFERENTIAL PRESSURE SENSOR

Provide maintenance reminder for filter change when Supply Air Filter Pressure Differential (DP-SA) is greater than or equal to the Supply Air Filter Pressure Differential Setpoint (DP-SA-SP).

COOLING COIL DX VARIABLE CONTROL (SINGLE COMPRESSOR)

Operate the compressor subject to the unit manufacturers standard safeties.

When in Occupied Mode:
The compressor remains off until Supply Air Fan (SF-ST) is proven on.

When in Cooling Mode or Dehumidification Mode:
Modulate the compressor to maintain the Supply Air Temperature (SAT) at the Supply Air Temperature Setpoint (SAT-SP).

When in Economizer Mode:
Cooling coil is second stage to economizer for cooling duty. Enable cooling coil only when Economizer Outside Air Damper is proven fully open. When enabled, modulate the compressor to maintain the Supply Air Temperature (SAT) at the Supply Air Temperature Setpoint (SAT-SP).

When in Heating Mode:
Turn off the compressor.

HEATING COIL - GAS MODULATED

Heating coil shall be initiated via manual override at the BAS. During startup, correlate minimum and maximum fan speed values (REF-CO-MIN, REF-CO-MAX) to maintain the Supply Air Temperature (SAT) at the Supply Air Temperature Setpoint (SAT-SP).

HEATING COIL - ELECTRIC MODULATING (SCR)

Operate the electric heating coil subject to the unit manufacturers standard safeties.
The electric heater remains off until Supply Air Fan (SF-ST) is proven on.

When in Occupied Mode:
When in Cooling Mode:
Turn off the coil.
When in Dehumidification Mode:
Turn off the coil.

When in Economizer Mode:
Turn off the coil.
When in Heating Mode:
Modulate coil to maintain the Return Air Temperature Setpoint (RAT-SP).

SUPPLY AIR TEMPERATURE RESET - DIRECT OUTSIDE AIR RESET

Linearly reset the Supply Air Temperature Setpoint (SAT-SP) based on the Outside Air Temperature Sensor (OAT) according to the following schedule:
Outside Air Temperature (OAT) Supply Air Temp Setpoint (SAT-SP)
OAT Reset Max Value (OAT-RST-MAX) SAT Minimum Setpoint (SAT-MIN)
OAT Reset Min Value (OAT-RST-MIN) SAT Maximum Setpoint (SAT-MAX)

When in Dehumidification Mode:
Set the Supply Air Temperature Setpoint (SAT-SP) to the SAT Minimum Setpoint (SAT-MIN).

SAFETIES, OVERRIDES, AND INTERLOCKS

SYSTEM-LEVEL OCCUPANCY OVERRIDE:

When in Unoccupied Mode:
System-Level Occupancy Override is based feedback from individual zone controls on its Occupancy Override Condition as defined in the sequence of operations of individual zone terminal units.
Override unit to Occupied Mode of operation when any associated zone terminal unit is experiencing an Occupancy Override.

Remove the System-Level Occupancy Override when every associated zone terminal unit is not experiencing an Occupancy Override.

FAULT DETECTION AND DIAGNOSTICS:

Include programmed controls for a fault detection and diagnostics (FDD) system. The FDD system shall include the following functionality:
Temperature sensors in the following locations and controls capable of displaying the value of each sensor:
Outside Air
Supply Air
Return Air

Configure controls to display and trend the following conditions:
Free cooling Available (when Economizer Mode is active)
Economizer Enabled (when Mixed Air Dampers are operating in Economizer Mode of operation)
Compressor Enabled (cooling coil command and/or command output)
Heating Enabled (heating coil command and/or command output)

Program controls to allow operator to manually initiate each operating mode so that the operation of components can be independently tested and verified.

Program the FDD system to be capable and configured to detect the following faults:
Air temperature sensor failure/fault
Not economizing when unit should be economizing
Economizing when the unit should not be economizing
Damper not modulating
Excess outdoor air

Program the FDD system to be capable of and configured to report faults to a fault management application or through the DDC system such that reports are accessible for operating or service personnel.

ELECTRIC HEATER FAN RELAY INTERLOCK:

Interlock the duct heater with RTU-1 via a relay. Do not energize the duct heater electric heating coil unless the associated fan is energized.

CONTROL LOOPS

SUPPLY FAN CONTROL - VARIABLE SPEED (MULTI ZONE VAV)

When the HOA switch is in hand position, operate the fan at the speed set manually by the operator at the user interface of the drive. When the HOA switch is in off position, turn the fan off. When the HOA switch is in auto position, operate the fan subject to the unit enable signal, and unit operating modes defined below.

During startup, correlate the fan speed settings to set fan operating points as detailed below:
Set the Supply Fan Minimum Speed Setpoint (SF-CO-MIN) based on the scheduled fan minimum airflow.
Set the Supply Fan Maximum Speed Setpoint (SF-CO-MAX) based on the scheduled fan maximum airflow.

Utilize a soft-start sequence when first energizing the fan. Fan initial setpoint shall be equal to the Supply Fan Minimum Speed Setpoint (SF-CO-MIN). Start the fan at its initial setpoint and slowly ramp up its speed to the current speed setpoint.

When in Occupied Mode:
Energize the fan and increase fan speed to its initial setpoint. Fan remains energized when in Occupied Mode.
Modulate fan between the Supply Fan Minimum Speed Setpoint (SF-CO-MIN) and the Supply Fan Maximum Speed Setpoint (SF-CO-MAX) to maintain the Supply Air Duct Static Pressure (SA-DSP) at the Supply Air Duct Static Pressure Setpoint (SA-DSP-SP).

When in Dehumidification Mode:
Operate as described in Occupied Mode.

When in Economizer Mode:
Operate as described in Occupied Mode.

RELIEF - EXHAUST FAN (REF) - BUILDING PRESSURE SENSOR CONTROL

When the HOA switch is in hand position, operate the fan at the speed set manually by the operator at the user interface of the drive. When the HOA switch is in off position, turn the fan off. When the HOA switch is in auto position, operate the fan subject to the unit enable signal, and unit operating modes defined below.

During startup, correlate minimum and maximum fan speed values (REF-CO-MIN, REF-CO-MAX) to maintain the Building Differential Pressure (BDP) at the Building Differential Pressure Setpoint (BDP-SP).
Fan initial setpoint shall be equal to the fan speed that correlates to the scheduled minimum airflow value. This value is the Relief-Exhaust Fan Minimum Speed Setpoint (REF-CO-MIN).

When in any mode:
Fan remains off until the Relief-Exhaust Air Damper is proven fully open.
When the Building Differential Pressure (BDP) is greater than the Building Differential Pressure Setpoint (BDP-SP) for duration exceeding the Pressure Control Delay (PC-DLY):
Energize the fan and increase fan speed to its initial setpoint.
Modulate fan between the Relief-Exhaust Fan Minimum Speed Setpoint (REF-CO-MIN) and the Relief-Exhaust Fan Maximum Speed Setpoint (REF-CO-MAX) to maintain the Building Differential Pressure (BDP) at the Building Differential Pressure Setpoint (BDP-SP).

When the Building Differential Pressure (BDP) is less than the Building Differential Pressure Setpoint (BDP-SP) and the fan is operating at the Relief-Exhaust Fan Minimum Speed Setpoint (REF-CO-MIN) for duration exceeding the Pressure Control Delay (PC-DLY):
Turn the fan off.

SEQUENCE OF OPERATIONS MULTIPLE ZONE VARIABLE AIR VOLUME AIR HANDLING UNIT (MZVAV/AHU)

GENERAL DESCRIPTION
The air handling unit(s) described by this sequence of operations consist(s) of a variable speed supply fan, direct expansion cooling coil and natural gas heating coil, MERV 13 filters, powered exhaust fan, and an energy recovery ventilator (ERV-1).

OPERATING MODES
Control shall be programmed to allow operator to manually initiate each operating mode so that the operation of components can be independently tested and verified.

OCCUPIED MODE:
The unit shall be in occupied mode per the Project Design Conditions Schedule shown on the control drawings.

COOLING MODE:
The unit shall not be capable of being in Cooling Mode and Heating Mode at the same time.
Once initiated, this mode shall remain active until Mode Switch Delay (MS-DLY) has elapsed.

When the unit shall enter Cooling Mode when:
The Mixed Air Temperature (MAT) is greater than the Supply Air Temperature Setpoint (SAT-SP) plus one half of the Supply Air Temperature Deadband (SAT-DB).

The unit shall exit Cooling Mode when:
The system enters Heating Mode.

HEATING MODE:
The unit shall not be capable of being in Cooling Mode and Heating Mode at the same time.
Once initiated, this mode shall remain active until Mode Switch Delay (MS-DLY) has elapsed.

The unit shall enter Heating Mode when:
The Return Air Temperature (OAT) is less than the Return Air Temperature Setpoint (RAT-SP).

The unit shall exit Heating Mode when:
The system enters Cooling Mode.

DEHUMIDIFICATION MODE - RETURN AIR RELATIVE HUMIDITY ENABLED:

Once initiated, this mode shall remain active until Mode Switch Delay (MS-DLY) has elapsed.

The unit shall enter Dehumidification Mode when:
Return Air Relative Humidity (RAH) is greater than the Return Air Relative Humidity Setpoint (RAH-SP).

The unit shall exit Dehumidification Mode when:
Return Air Relative Humidity (RAH) is less than the Return Air Relative Humidity Setpoint (RAH-SP) minus the Return Air Relative Humidity Hysteresis (RAH-HB).

ECONOMIZER MODE - FIXED ENTHALPY WITH FIXED DRY-BULB TEMPERATURE ENABLED:

The unit shall be in Economizer Mode when all of the following are true:
The supply fan status is on
The unit is in Cooling Mode or Dehumidification Mode
The unit is not in Freeze Protection Mode level 2
The Return Air Enthalpy (OAE) is less than the Economizer Outside Air Enthalpy High Limit (OAE-HL)
The Outside Air Temperature (OAT) is less than the Economizer Outdoor Air Dry Bulb High Limit (OAT-HL).

The unit shall exit Economizer Mode when any of the following are true:
The supply fan status is off
The unit enters Heating Mode
The unit enters Freeze Protection Mode Level 2
The Outside Air Enthalpy (OAE) is greater than the Economizer Outside Air Enthalpy High Limit (OAE-HL)
The Outside Air Temperature (OAT) is greater than the Economizer Outdoor Air Dry Bulb High Limit (OAT-HL).

LOSS OF POWER RESTART DELAY MODE:

The unit shall be in Loss of Power Restart Delay mode upon restoration of power after an unexpected loss of power. The unit shall remain in this mode for the duration as defined by the Unit Start Delay (USD) setpoint. Once the unit start delay duration has elapsed, the unit shall return to the previous mode prior to loss of power. Include logic that randomizes the restart time of various HVAC components in the system to mitigate the potential for a rebound peak.

CONTROL SETPOINT RESETS

SUPPLY FAN STATIC PRESSURE RESET - TRIM AND RESPOND:

Reset the Supply Air Duct Static Pressure Setpoint (SA-DSP-SP) using Trim and Respond Logic within the Duct Static Pressure Minimum Setpoint (DSP-MIN) and Duct Static Pressure Maximum Setpoint (DSP-MAX).

When the fan is commanded off, return the Duct Static Pressure Setpoint (DSP-SP) to the Duct Static Pressure Default Setpoint (DSP-D).

Current Number of Requests Logic:
Reset requests are generated by the Mechanical Control System based on information from associated zone equipment. In this case, zone equipment refers to air terminal units served by the fan system. Refer to the contract documents for more information on system associations.

For each individual associated zone unit, calculate the number of requests based on the following criteria. Refer to zone terminal unit points list for point names referenced below.
If the measured zone Primary Airflow (CFM) is less than 50% of Primary Airflow Setpoint (CFM-MAX) and the zone Damper Position (P) is greater than 95% open, send 3 requests.
If the measured zone Primary Airflow (CFM) is between 50% and 70% of Primary Airflow Setpoint (CFM-MAX) and the zone Damper Position (P) is greater than 95% open, send 2 requests.
If the measured zone Primary Airflow (CFM) is between 70% and 100% of Primary Airflow Setpoint (CFM-MAX) and the zone Damper Position (P) is greater than 95% open, send 1 request.

If the Damper Position (P) is less than 95% open, send 0 requests.
The control system shall be capable of excluding zones from the analysis.

Trim and Respond Logic:
Activate trim and respond logic after the fan is commanded on and Trim and Respond Time Delay (TR-TD) has elapsed.
When trim and respond logic is active, collect Current Number of Requests (TR-R) from zone equipment at time intervals defined by Trim and Respond Time Step (TR-T).

If the Current Number of Requests (TR-R) is less than or equal to the Number of Ignored Requests (TR-I), trim the setpoint by the Trim Amount (TR-TRIM).

If the Current Number of Requests (TR-R) is greater than the Number of Ignored Requests (TR-I), respond by changing the setpoint by the formula:
TR-RES*(TR-R - TR-I)

The setpoint may not be reset more than the Maximum Respond Amount (TR-RES-MAX) in any given time step.

Architect's Name	License #	Date
Issue	Date	

Drawn by: Auditor
Copyright © 2024 by HMN Architects, Inc.

MECHANICAL CONTROLS

CONTROL SETPOINT RESETS
Not Used.
SAFETIES, OVERRIDES AND INTERLOCKS
MANUAL TEMPERATURE SETPOINT OVERRIDE:
Reset the current zone temperature setpoint based on occupant manual temperature setpoint adjustment (Z-TA).
Return the current zone temperature setpoint to its default value after manual temperature setpoint adjust delay (Z-TA-DLY) has elapsed.
COMPONENT CONTROL LOOPS
PRIMARY AIR DAMPER - SINGLE MAXIMUM, SINGLE MINIMUM
Correlate the minimum primary airflow setpoint and design primary airflow cooling setpoint to a 0-10 Vac signal for each box.
When in Occupied Mode:
When in Cooling Mode:
Modulate the primary air damper to vary airflow between the Primary Airflow Setpoint (CFM-MAX) and the Minimum Primary Airflow Setpoint (CFM-MIN) as required to maintain the Zone Temperature Cooling Setpoint (Z-T-C). An increase in room temperature causes airflow to increase.

SEQUENCE OF OPERATIONS: SINGLE DUCT VAV BOX

GENERAL DESCRIPTION
The air terminal units described by this sequence consist of a single duct variable air volume box with a primary air damper and airflow measuring station.

OPERATING MODES
OCCUPIED MODE:
The unit shall be in occupied mode per the Project Design Conditions schedule shown on the control drawings.
COOLING MODE:
When in Occupied Mode:
The unit shall be in cooling mode when the Zone Temperature (Z-T) is greater than the Zone Temperature Cooling Setpoint (Z-T-C).
LOSS OF POWER RESTART DELAY MODE:
The unit shall be in Loss of Power Restart Delay mode upon restoration of power after an unexpected loss of power. The unit shall remain in this mode for the duration as defined by the Unit Start Delay (USD) setpoint. Once the unit start delay duration has elapsed, the unit shall return to the previous mode prior to loss of power. Include logic that randomizes the restart time of various HVAC components in the system to mitigate the potential for a rebound peak.

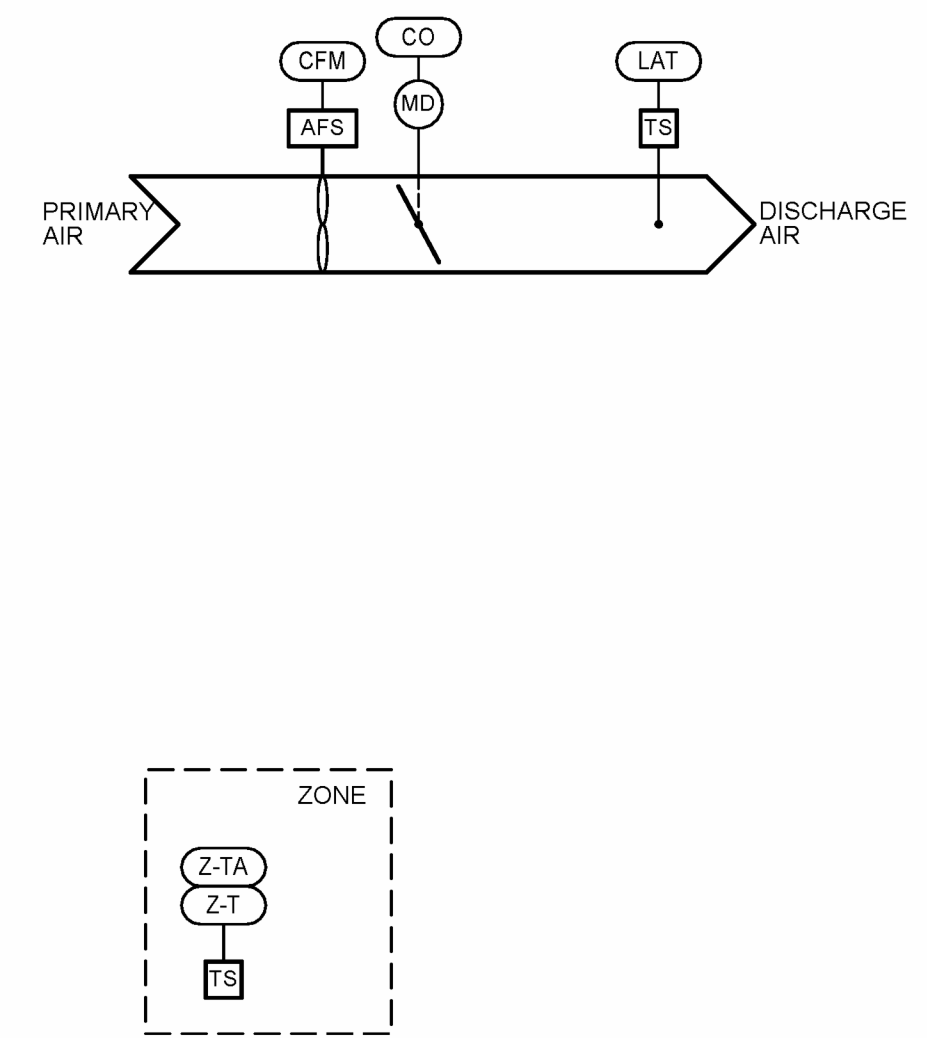
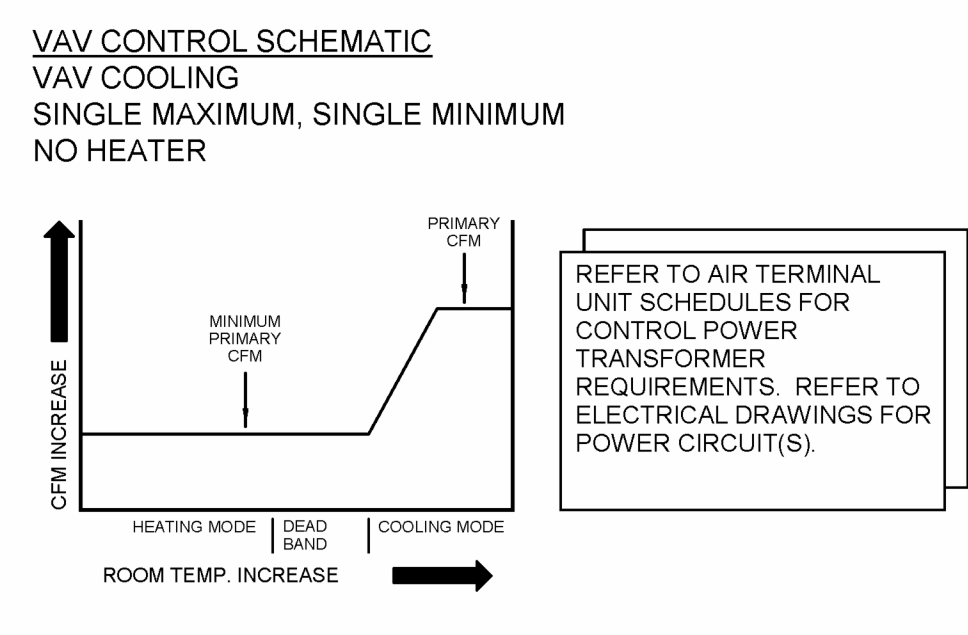

④ TERMINAL UNIT (VAV-1-22) CONTROL DIAGRAM
NTS

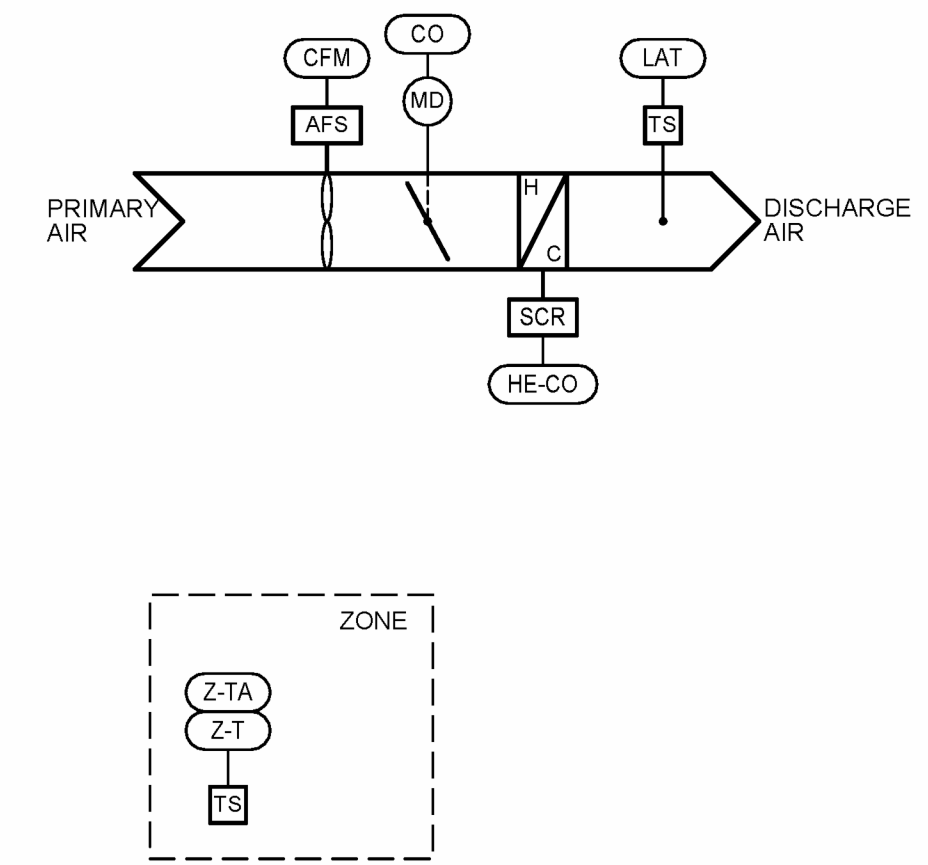
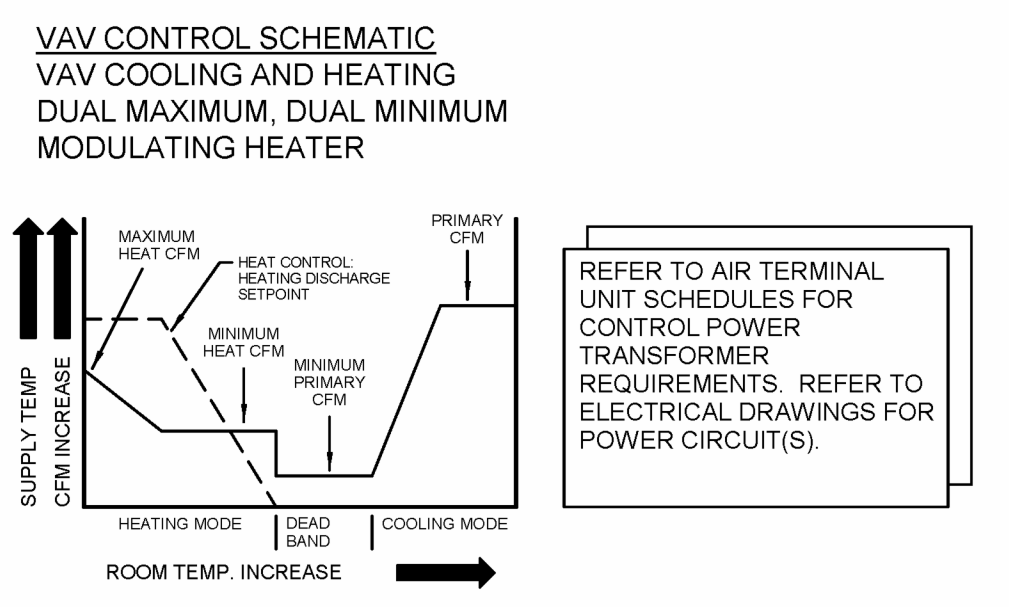

① TERMINAL UNIT CONTROL DIAGRAM
12" = 1'-0"

POINT ID	DESCRIPTION	POINT TYPE	SETPOINT	FAIL POSITION	TRENDING STORAGE	GRAPHIC DISPLAY	STATUS ALARM	ALARM RANGE	NOTES
POINTS LIST - SINGLE DUCT VAV BOX									
GLOBAL VALUES									
USD	UNIT START DELAY	AV	15 MIN						D
ZONE LEVEL SENSORS									
Z-T	ZONE TEMPERATURE	AI	SCHED		X	X			A, D
Z-T-H	ZONE TEMPERATURE HEATING SETPOINT	AV	SCHED		X				C, D
Z-T-C	ZONE TEMPERATURE COOLING SETPOINT	AV	SCHED		X				C, D
Z-TA	MANUAL TEMPERATURE SETPOINT ADJUST	AI	+/- 2 F		X	X			C, D
Z-TA-DLY	MANUAL TEMPERATURE SETPOINT ADJUST DELAY	AV	2 HR			X			D
SINGLE DUCT BOX									
CFM	PRIMARY AIRFLOW	AI			X	X			
CFM-MAX	PRIMARY AIRFLOW SETPOINT	AV	SCHED		X				D
CFM-MIN	MINIMUM PRIMARY AIRFLOW SETPOINT	AV	SCHED		X				D
CFM-H-MAX	MAXIMUM HEATING AIRFLOW SETPOINT	AV	SCHED		X				D
CFM-H-MIN	MINIMUM HEATING AIRFLOW SETPOINT	AV	SCHED		X				D
CO	PRIMARY AIR DAMPER CONTROL OUTPUT	AO			X	X			
LAT	LEAVING AIR TEMPERATURE	AI			X	X			
LAT-H-MAX	MAXIMUM LEAVING AIR TEMPERATURE HEATING SETPOINT	AV	SCHED		X	X			D
TERMINAL HEATING COIL - ELECTRIC SCR MODULATING									
HE-CO	ELECTRIC HEAT SCR CONTROL OUTPUT	AO			X	X			

NOTES:
A. REFERENCE GLOBAL BUILDING MONITORING SCHEDULE FOR CONTROL POINT.
C. REFERENCE PROJECT DESIGN CONDITIONS SCHEDULE FOR SETPOINT.
D. POINT SHALL BE ADJUSTABLE.

POINT ID	DESCRIPTION	POINT TYPE	SETPOINT	SETPOINT RESET RANGE	FAIL POSITION	TRENDING INTERVAL	TRENDING STORAGE	GRAPHIC DISPLAY	STATUS ALARM	ALARM RANGE	NOTES
POINTS LIST - SINGLE DUCT VAV BOX											
GLOBAL VALUES											
USD	UNIT START DELAY	AV	15 MIN								D
ZONE LEVEL SENSORS											
Z-T	ZONE TEMPERATURE	AI	SCHED				X	X			A, D
Z-T-C	ZONE TEMPERATURE COOLING SETPOINT	AV	76 F				X				C, D
Z-TA	MANUAL TEMPERATURE SETPOINT ADJUST	AI	+/- 2 F				X	X			C, D
Z-TA-DLY	MANUAL TEMPERATURE SETPOINT ADJUST DELAY	AV	2 HR					X			D
SINGLE DUCT BOX											
CFM	PRIMARY AIRFLOW	AI		SCHED			X	X			
CFM-MAX	PRIMARY AIRFLOW SETPOINT	AV	SCHED				X				D
CFM-MIN	MINIMUM PRIMARY AIRFLOW SETPOINT	AV	SCHED				X				D
CO	PRIMARY AIR DAMPER CONTROL OUTPUT	AO					X	X			

ALL POINTS SHOWN SHALL BE PROVIDED BY BAS CONTRACTOR UNLESS NOTED OTHERWISE.
PROVIDE UNIQUE POINT NAME FOR EACH CONTROL POINT CONSISTENT WITH THE MARK IDENTIFIER ON THE EQUIPMENT SCHEDULE (E.G. RH01-D-C).
REFER TO SPECIFICATION FOR ADDITIONAL REQUIREMENTS.

NOTES:
A. REFERENCE GLOBAL BUILDING MONITORING SCHEDULE FOR CONTROL POINT.
C. REFERENCE PROJECT DESIGN CONDITIONS SCHEDULE FOR SETPOINT.
D. POINT SHALL BE ADJUSTABLE.

HEATING COIL - ELECTRIC SCR - MODULATING WITH DUAL MAXIMUM
When in Occupied Mode:
When in Cooling Mode:
Turn the coil OFF.
When in Heating Mode:
When the Primary Airflow (CFM) is at the Minimum Heating Airflow Setpoint (CFM-H-MIN):
Modulate the heating coil as required to maintain the Zone Temperature Heating Setpoint (Z-T-H).
When the Leaving Air Temperature (LAT) has reached the Maximum Leaving Air Temperature Heating Setpoint (LAT-H-MAX):
Modulate the coil to maintain constant Leaving Air Temperature equal to the Leaving Air Temperature Heating Setpoint (LAT-H-MAX).

MANUAL TEMPERATURE SETPOINT OVERRIDE:
Reset the current zone temperature setpoint based on occupant manual temperature setpoint adjustment (Z-TA).
Return the current zone temperature setpoint to its default value after manual temperature setpoint adjust delay (Z-TA-DLY) has elapsed.
ELECTRIC HEATER AIRFLOW INTERLOCK:
The unit electric heating coil shall not energize unless minimum airflow is across the heating coil.
COMPONENT CONTROL LOOPS
PRIMARY AIR DAMPER - DUAL MAXIMUM, DUAL MINIMUM
Correlate the minimum primary airflow setpoint and design primary airflow cooling setpoint to a 0-10 Vac signal for each box.
When in Occupied Mode:
When in Cooling Mode:
Modulate the primary air damper to vary airflow between the Primary Airflow Setpoint (CFM-MAX) and the Minimum Primary Airflow Setpoint (CFM-MIN) as required to maintain the Zone Temperature Cooling Setpoint (Z-T-C). An increase in room temperature causes airflow to increase.
When in Deadband Mode:
Modulate the primary air damper to maintain airflow at the Minimum Primary Airflow Setpoint (CFM-MIN).
When in Heating Mode:
When the Leaving Air Temperature (LAT) is less than the Maximum Leaving Air Temperature Heating Setpoint (LAT-H-MAX):
Modulate the primary air damper to maintain airflow at the Minimum Heating Airflow Setpoint (CFM-H-MIN).
When the Leaving Air Temperature (LAT) is equal to the Maximum Leaving Air Temperature Heating Setpoint (LAT-H-MAX):
Modulate the primary air damper to vary airflow between the Maximum Heating Airflow Setpoint (CFM-H-MAX) and the Minimum Heating Airflow Setpoint (CFM-H-MIN) as required to maintain the Zone Temperature Heating Setpoint (Z-T-H). A decrease in room temperature causes airflow to increase.

SEQUENCE OF OPERATIONS: SINGLE DUCT VAV BOX

GENERAL DESCRIPTION
The air terminal units described by this sequence consist of a primary air damper and an electric resistance heating coil.

OPERATING MODES
OCCUPIED MODE:
The unit shall be in occupied mode per the Project Design Conditions schedule shown on the control drawings.
COOLING MODE:
When in Occupied Mode:
The unit shall be in cooling mode when the Zone Temperature (Z-T) is greater than the Zone Temperature Cooling Setpoint (Z-T-C).
DEADBAND MODE:
When in Occupied Mode:
The unit shall be in Deadband Mode when the Zone Temperature (Z-T) is between the Zone Temperature Cooling Setpoint (Z-T-C) and the Zone Temperature Heating Setpoint (Z-T-H).
HEATING MODE:
When in Occupied Mode:
The unit shall be in heating mode when the Zone Temperature (Z-T) is less than the Zone Temperature Heating Setpoint (Z-T-H).
LOSS OF POWER RESTART DELAY MODE:
The unit shall be in Loss of Power Restart Delay mode upon restoration of power after an unexpected loss of power. The unit shall remain in this mode for the duration as defined by the Unit Start Delay (USD) setpoint. Once the unit start delay duration has elapsed, the unit shall return to the previous mode prior to loss of power. Include logic that randomizes the restart time of various HVAC components in the system to mitigate the potential for a rebound peak.

CONTROL SETPOINT RESETS
Not Used.
SAFETIES, OVERRIDES AND INTERLOCKS
MANUAL OCCUPANCY OVERRIDE:
When in Unoccupied Mode:
Override unit to Occupied Mode of operation based on input from Zone Manual Occupancy override (Z-OR). Override shall persist until Zone Occupancy Override Delay (Z-OCC-DLY) has elapsed.

HENDERSON ENGINEERS
8345 LENEVA DRIVE, SUITE 300
LENEVA, ILLINOIS 62454
TEL 913.742.9500 FAX 913.742.5001
WWW.HENDERSONENGINEERS.COM
225004109
IL CORPORATE NO. 184-002985
EXPIRES 4/30/2026
EXPIRES ON: 11/30/2025



03/01/2024

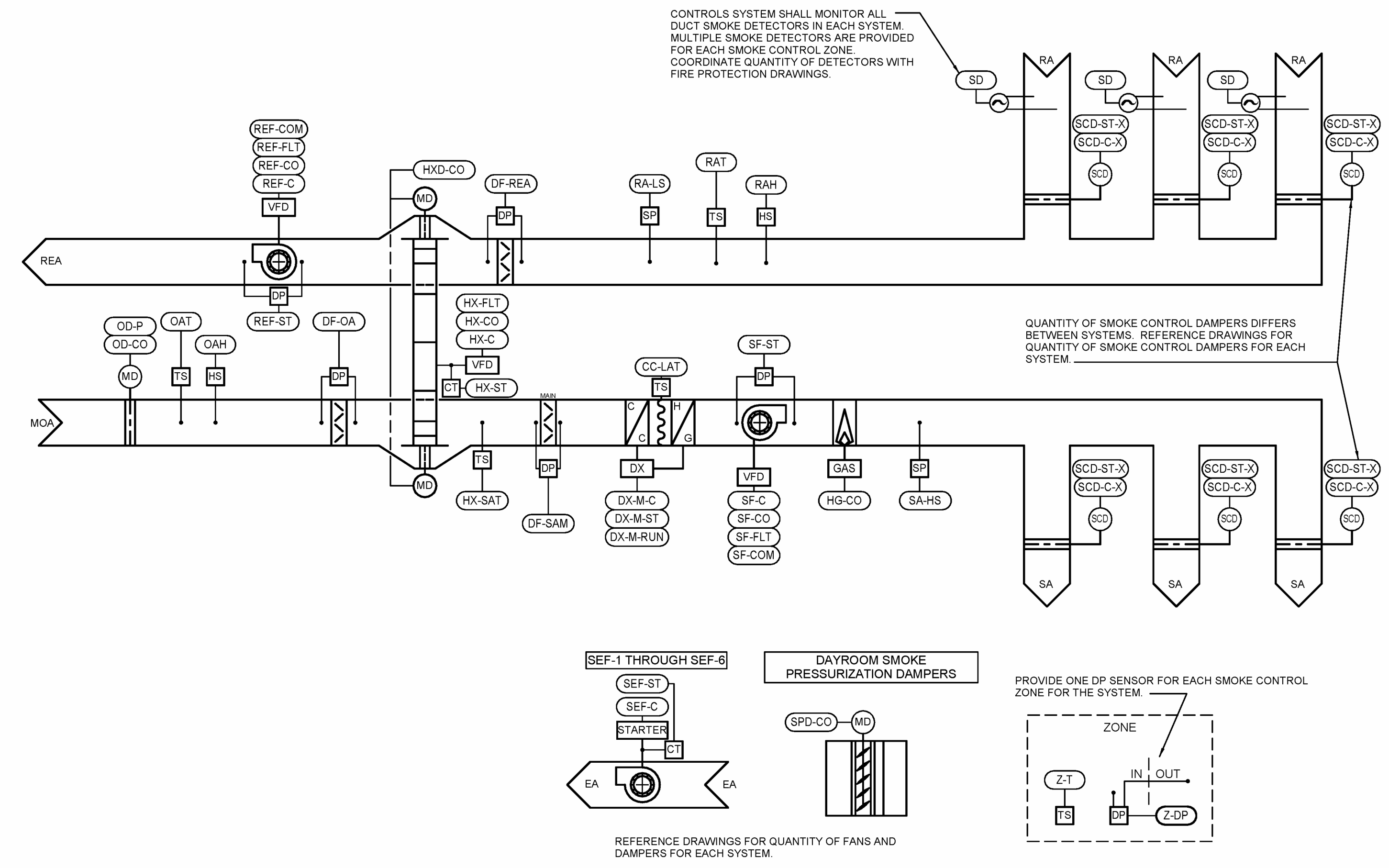

1 RTU-2 AND RTU-3 CONTROL DIAGRAM

SEQUENCE OF OPERATIONS
 100% OUTSIDE AIR SINGLE ZONE CONSTANT AIR VOLUME AIR HANDLING UNIT (100% SZCV AHU)
GENERAL DESCRIPTION
 The air handling unit(s) described by this sequence of operations consist(s) of supply fan, exhaust fan, energy recovery wheel, direct expansion (DX) cooling coil, hot gas reheat coil, and a natural gas heating coil.

OPERATING MODES
 Control shall be programmed to allow operator to manually initiate each operating mode so that the operation of components can be independently tested and verified.

OCCUPIED MODE:
 The unit shall be in occupied mode per the Project Design Conditions Schedule shown on the control drawings.

COOLING MODE:
 The unit shall not be capable of being in Cooling Mode and Heating Mode at the same time.

Once initiated, this mode shall remain active until Mode Switch Delay (MS-DLY) has elapsed.

When in Occupied Mode:
 The unit shall be in cooling mode when the Zone Temperature (Z-T) is greater than the Zone Temperature Cooling Setpoint (Z-T-C).

HEATING MODE:
 The unit shall not be capable of being in Cooling Mode and Heating Mode at the same time.

Once initiated, this mode shall remain active until Mode Switch Delay (MS-DLY) has elapsed.

When in Occupied Mode:
 The unit shall be in heating mode when the Zone Temperature (Z-T) is less than the Zone Temperature Heating Setpoint (Z-T-H).

DEHUMIDIFICATION MODE - RELATIVE HUMIDITY ENABLED:
 Once initiated, this mode shall remain active until Mode Switch Delay (MS-DLY) has elapsed.

The unit shall enter Dehumidification Mode when:
 Zone Relative Humidity (Z-H) is greater than the Zone Relative Humidity Setpoint (Z-H-SP).
 And- The unit is not in Cooling Mode.

The unit shall exit Dehumidification Mode when:
 Zone Relative Humidity (Z-H) is less than the Zone Relative Humidity Setpoint (Z-H-SP) minus the Zone Relative Humidity Deadband (Z-H-DB).
 Or- The unit is in Cooling Mode.

ECONOMIZER MODE - FIXED ENTHALPY WITH FIXED DRY-BULB TEMPERATURE ENABLED:
 The unit shall be in Economizer Mode when all of the following are true:
 The supply fan status is on
 The unit is in Cooling Mode or Dehumidification Mode
 The Outside Air Enthalpy (OAE) is less than the Economizer Outside Air Enthalpy High Limit (OAE-HL).
 The Outside Air Temperature (OAT) is less than the Economizer Outdoor Air Dry Bulb High Limit (OAT-HL).
 The unit shall exit Economizer Mode when any of the following are true:
 The supply fan status is off
 The unit enters Heating Mode
 The unit enters Dehumidification Mode
 The unit enters Freeze Protection Mode Level 2
 The Outside Air Enthalpy (OAE) is greater than the Economizer Outside Air Enthalpy High Limit (OAE-HL).
 The Outside Air Temperature (OAT) is greater than the Economizer Outdoor Air Dry Bulb High Limit (OAT-HL).

ENERGY RECOVERY ECONOMIZER MODE:
 When the unit is in Economizer Mode it shall also be in Energy Recovery Economizer Mode. Refer to the Economizer Mode definition above.

ENERGY RECOVERY HEATING MODE- TEMPERATURE ENABLED:
 The unit shall be in Energy Recovery Heating Mode when:
 The unit is in Heating Mode
 The unit shall exit Energy Recovery Heating Mode when:
 The unit is in Cooling Mode
 The unit is in Economizer Mode
 Or- the unit is in Energy Recovery Frost Prevention Mode.

ENERGY RECOVERY FROST PREVENTION MODE- OA SENSING:
 The unit shall be in Energy Recovery Frost Prevention Mode when:
 The Outdoor Air Temperature (OAT) is less than the Outside Air Defrost Setpoint (OA-DF-SP).
 And- The Heat Recovery Differential Pressure (HR-DP) is greater than the Heat Recovery Differential Pressure Setpoint (HR-DP-SP).

The unit shall exit Energy Recovery Frost Prevention Mode when:
 The Outdoor Air Temperature (OAT) is greater than the Outside Air Defrost Setpoint (OA-DF-SP).
 Or- The Heat Recovery Differential Pressure (HR-DP) is greater than the Heat Recovery Differential Pressure Setpoint (HR-DP-SP) for a duration exceeding Frost Control Delay (FC-DLY).

LOSS OF POWER RESTART DELAY MODE:
 The unit shall be in Loss of Power Restart Delay mode upon restoration of power after an unexpected loss of power. The unit shall remain in this mode for the duration as defined by the Unit Start Delay (USD) setpoint. Once the unit start delay duration has elapsed, the unit shall return to the previous mode prior to loss of power. Include logic that randomizes the restart time of various HVAC components in the system to mitigate the potential for a rebound peak.

SMOKE CONTROL MODE:
 The unit shall be in smoke control mode upon signal from the fire alarm control panel (FA-ST). Smoke control mode shall be initiated by the fire alarm controller whenever any exhaust air smoke detector in the system senses smoke.

CONTROL SETPOINT RESETS
 Not Used.

SAFETIES, OVERRIDES, AND INTERLOCKS
HIGH SUPPLY AIR STATIC PRESSURE INTERLOCK:
 The unit shall be disabled via hard wired interlock at the fan start circuit upon activation of the Supply Duct High Static Controller (SA-HS).

The unit shall require a manual reset.

LOW RETURN AIR STATIC PRESSURE INTERLOCK:
 The unit shall be disabled via hard wired interlock at the fan start circuit upon activation of the Return Air Low Static Controller (RA-LS).

The unit shall require a manual reset.

FAULT DETECTION AND DIAGNOSTICS:
 Include programmed controls for a fault detection and diagnostics (FDD) system. The FDD system shall include the following functionality:
 Temperature sensors in the following locations and controls capable of displaying the value of each sensor:
 Outside Air
 Supply Air
 Return Air
 Configure controls to display and trend the following conditions:
 Free cooling Available (when Economizer Mode is active)
 Economizer Enabled (when Mixed Air Dampers are operating in Economizer Mode of operation)
 Compressor Enabled (cooling coil command and/or command output)
 Heating Enabled (heating coil command and/or command output)

Program controls to allow operator to manually initiate each operating mode so that the operation of components can be independently tested and verified.
 Program the FDD system to be capable and configured to detect the following faults:
 Air temperature sensor failure/fault
 Not economizing when unit should be economizing
 Economizing when unit should not be economizing
 Damper not modulating
 Excess outdoor air
 Program the FDD system to be capable of and configured to report faults to a fault management application or through the DDC system such that reports are accessible for operating or service personnel.

CONTROL LOOPS
SUPPLY FAN CONTROL - CONSTANT VOLUME
When in Occupied Mode:
 Energize the supply fan and operate continuously.

When in Smoke Control Mode:
 Operate as described in Occupied Mode.

RELIEF - EXHAUST FAN (REF) - CONSTANT VOLUME CONTROL
 Fan remains off until the Relief-Exhaust Air Damper is proven fully open.

When in Occupied Mode:
 Energize the supply fan and operate continuously.

When in Smoke Control Mode:
 Operate as described in Occupied Mode.

OUTSIDE AIR DAMPER (2 POSITION CONTROL)
When in Occupied Mode:
 Open the damper.

When in Smoke Control Mode:
 Open the damper.

OUTSIDE AIR FILTER MONITORING - DIFFERENTIAL PRESSURE SENSOR
 Provide maintenance reminder for filter change when Outside Air Filter Pressure Differential (DF-OA) is greater than or equal to the Outside Air Filter Pressure Differential Setpoint (DF-OA-SP).

RELIEF/EXHAUST AIR FILTER MONITORING - DIFFERENTIAL PRESSURE SENSOR
 Provide maintenance reminder for filter change when Relief/Exhaust Air Filter Pressure Differential (DF-REA) is greater than or equal to the Relief/Exhaust Air Filter Pressure Differential Setpoint (DF-REA-SP).

COOLING COIL DX STAGED CONTROL
 Operate the compressor(s) subject to the unit manufacturers standard safeties.

When in Occupied Mode:
 The compressor(s) remain off until Supply Air Fan (SF-ST) is proven on.
 When in Cooling Mode:
 Stage the compressor(s) to maintain the Zone Temperature (Z-T) at the Zone Temperature Cooling Setpoint (Z-T-C).
 When in Economizer Mode:
 Operate as described in Cooling Mode.
 When in Dehumidification Mode:
 Dehumidification Mode operation shall take precedence over Cooling Mode operation.
 Operate the compressor(s) to provide cooling at full capacity.
 When in Heating Mode:
 Turn off the compressor(s).

When in Heating Mode:
 Modulate coil to maintain the Zone Temperature (Z-T) at the Zone Temperature Heating Setpoint (Z-T-H).

When in Smoke Control Mode:
 Operate as described in occupied mode.

HOT GAS REHEAT COIL - MODULATING
 Enable hot gas reheat and modulate the hot gas reheat capacity as required to maintain the Zone Temperature (Z-T) at the Zone Temperature Cooling Setpoint (Z-T-C).

When not in Dehumidification Mode:
 Disable hot gas reheat.

HEAT RECOVERY - ENERGY RECOVERY WHEEL - VARIABLE SPEED
When in Occupied Mode:
 When in Energy Recovery Cooling Mode:
 Turn the energy recovery wheel on. Modulate the wheel to its design speed for 100% capacity.
 When in Energy Recovery Economizer Mode:
 Turn the energy recovery wheel off.
 When in Energy Recovery Heating Mode:
 Turn the energy recovery wheel on. Modulate the wheel to its design speed for 100% capacity.
 When in Energy Recovery Frost Prevention Mode:
 Turn the energy recovery wheel on. Modulate the wheel to its design speed for 100% capacity.

HEAT RECOVERY BYPASS DAMPERS
 The bypass dampers shall be linked in an inverse correlation such that opening the Heat Recovery Bypass Damper will close the associated damper as shown in the control schematic.

When in Energy Recovery Economizer Mode:
 Open the damper(s).

When not in Energy Recovery Economizer Mode:
 Close the damper(s).

SMOKE EXHAUST FAN
 SMOKE EXHAUST FAN COMMENT (START/STOP)
 SMOKE EXHAUST FAN STATUS

OUTSIDE AIR DAMPER
 OUTSIDE AIR DAMPER COMMAND
 OUTSIDE AIR DAMPER STATUS

SMOKE PRESSURIZATION DAMPER (MODULATING)
 SMOKE PRESSURIZATION DAMPER CONTROL OUTPUT
 SMOKE CONTROL DAMPER (2-POSITION)
 SMOKE ZONE CONTROL DAMPER COMMAND
 SMOKE ZONE CONTROL DAMPER STATUS

SUPPLY AIR DIRTY FILTER INDICATION
 SUPPLY AIR FILTER PRESSURE DIFFERENTIAL
 SUPPLY AIR FILTER PRESSURE DIFFERENTIAL SETPOINT

OUTSIDE AIR DIRTY FILTER INDICATION
 OUTSIDE AIR FILTER PRESSURE DIFFERENTIAL
 OUTSIDE AIR FILTER PRESSURE DIFFERENTIAL SETPOINT

RELIEF/EXHAUST AIR DIRTY FILTER INDICATION
 RELIEF/EXHAUST AIR FILTER PRESSURE DIFFERENTIAL
 RELIEF/EXHAUST AIR FILTER PRESSURE DIFFERENTIAL SETPOINT

COOLING COIL - DX VARIABLE CONTROL
 DX-M-CO DX MODULATING COMPRESSOR CONTROL OUTPUT
 DX-M-ST DX MODULATING COMPRESSOR STATUS
 DX-M-RUN DX MODULATING COMPRESSOR RUNTIME

DEHUMIDIFICATION
 Z-H-SP ZONE HUMIDITY SETPOINT
 Z-H-DB ZONE HUMIDITY DEADBAND

HOT GAS REHEAT COIL - DEHUMIDIFICATION
 HGRH-C HOT GAS REHEAT COMMAND
 HGRH-CO HOT GAS REHEAT CONTROL OUTPUT

HEATING COIL - GAS FURNACE MODULATING
 HG-CO GAS FURNACE HEAT MODULATION CONTROL OUTPUT

ENERGY RECOVERY - AIR SENSING
 OAT-D-SP OUTSIDE AIR DEFROST SETPOINT
 FC-DLY FROST CONTROL DELAY
 HR-DP HEAT RECOVERY DIFFERENTIAL PRESSURE
 HR-DP-SP HEAT RECOVERY DIFFERENTIAL PRESSURE SETPOINT

ENERGY RECOVERY - WHEEL CONSTANT SPEED
 HR-C HEAT RECOVERY WHEEL COMMAND
 HR-ST HEAT RECOVERY WHEEL STATUS

ALL POINTS SHOWN SHALL BE PROVIDED BY BAS CONTRACTOR UNLESS NOTED OTHERWISE.
 PROVIDE UNIQUE POINT NAME FOR EACH CONTROL POINT CONSISTENT WITH THE MARK IDENTIFIER ON THE EQUIPMENT SCHEDULE (E.G. RH01-D-C).
 REFER TO SPECIFICATION FOR ADDITIONAL REQUIREMENTS.

NOTES:
 A. REFERENCE GLOBAL BUILDING MONITORING SCHEDULE FOR CONTROL POINT.
 B. REFERENCE PROJECT DESIGN CONDITIONS SCHEDULE OR EQUIPMENT SCHEDULE FOR SETPOINT AS APPROPRIATE.
 C. POINT SHALL BE ADJUSTABLE.
 D. DETERMINE SETPOINT DURING TESTING AND BALANCING. COORDINATE WITH THE TEST AND BALANCE CONTRACTOR.
 E. DEVICE AND RELAY FROM FROST ALARM SYSTEM PROVIDED BY DIVISION 28. DISPLAY DETECTOR RELAY STATUS (NORMAL/ALARM) AT BAS FRONT END.
 F. SA CALCULATED VALUE BASED ON MEASURED AIR PROPERTIES AND PSYCHROMETRIC EQUATIONS.
 G. K. STATIC PRESSURE SHALL BE TIME-AVERAGED WITH A SLIDING 5-MINUTE WINDOW AND 15 SECOND SAMPLING RATE (TO DAMPEN FLUCTUATIONS). THE AVERAGED VALUE SHALL BE DISPLAYED AND USED FOR CONTROL.

1.01

POINTS LIST - 100% OUTSIDE AIR SINGLE ZONE CONSTANT VOLUME AHU

POINT ID	DESCRIPTION	POINT TYPE	DEFAULT SETPOINT	FAIL POSITION	TRENDING STORAGE	GRAPHIC DISPLAY	STATUS ALARM	ALARM RANGE	NOTES
GLOBAL VALUES									
OAT	OUTSIDE AIR TEMPERATURE	AV			X	X			A
USD	UNIT START DELAY	AV	10 MIN						D
MS-DLY	MODE SWITCH DELAY	AV	2 MIN						D
RST-DLY	RESET DELAY	AV	3 MIN						D
ZONE LEVEL SENSORS									
Z-T	ZONE TEMPERATURE	AI			X	X			
Z-T-C	ZONE TEMPERATURE COOLING SETPOINT	AV	75 F		X				C.D
Z-T-C-SB	ZONE TEMPERATURE COOLING SETBACK SETPOINT	AV	80 F		X				C.D
Z-T-H	ZONE TEMPERATURE HEATING SETPOINT	AV	70 F		X				C.D
Z-T-H-SB	ZONE TEMPERATURE HEATING SETBACK SETPOINT	AV	60 F		X				C.D
ZDP	ZONE DIFFERENTIAL PRESSURE	AI			X	X			K
ZDP-SP	ZONE DIFFERENTIAL PRESSURE SETPOINT	AV	0.05 INWG		X				D.E
AIR SENSING									
SA-HS	SUPPLY DUCT HIGH STATIC CONTROLLER	BI	2.0 INWG				X		ON ACTIVATION D
RAT	RETURN AIR TEMPERATURE	AI			X	X			
RAH	RETURN AIR HUMIDITY	AI			X	X			
RA-LS	RETURN AIR LOW STATIC CONTROLLER	BI	-1.0 INWG				X		ON ACTIVATION D
OAE	OUTSIDE AIR ENTHALPY	AV			X	X	X		
HC-LAT	HEATING COIL LEAVING AIR TEMPERATURE	AI			X	X			I
CC-LAT	COOLING COIL LEAVING AIR TEMPERATURE	AI			X	X			
ECONOMIZER MODE - FIXED ENTHALPY WITH FIXED DRY-BULB TEMPERATURE ENABLED									
OAT-HL	ECONOMIZER OUTDOOR AIR DRY BULB HIGH LIMIT	AV	76 F		X				D
OAE-HL	ECONOMIZER OUTSIDE AIR ENTHALPY HIGH LIMIT	AV	28 BTU/LB		X				D
FIRE ALARM CONTROL PANEL RELAY INTERLOCK									
FA-SD	FIRE ALARM SHUTDOWN AND STATUS	BI					X	X	ON ACTIVATION H
SUPPLY FAN									
SF-COM	SUPPLY FAN VFD COMMUNICATION	COM				X			
SF-C	SUPPLY FAN COMMAND (ENABLE/DISABLE)	BO			X	X			
SF-CO	SUPPLY FAN CONTROL OUTPUT - SPEED (PERCENT)	AV			X	X			
SF-CO-MIN	SUPPLY FAN MINIMUM SPEED SETPOINT	AV	() HZ		X				D.E
SF-CO-LOW	SUPPLY FAN LOW SPEED SETPOINT	AV	() HZ		X				D.E
SF-CO-HIGH	SUPPLY FAN HIGH SPEED SETPOINT	AV	() HZ		X				D.E
SF-ST	SUPPLY FAN STATUS	BI			X	X	X		SF-ST <=> SF-C
SF-FLT	SUPPLY FAN VFD FAULT	BV			X	X	X		COMMON ALARM
RELIEF-EXHAUST FAN									
REF-COM	RELIEF-EXHAUST FAN VFD COMMUNICATION	COM				X			
REF-C	RELIEF-EXHAUST FAN COMMAND (ENABLE/DISABLE)	BO			X	X			
REF-CO	RELIEF-EXHAUST FAN CONTROL OUTPUT - SPEED (PERCENT)	AV			X	X			
REF-CO-MIN	RELIEF-EXHAUST FAN MINIMUM SPEED SETPOINT	AV	() HZ		X				D.E
REF-CO-MAX	RELIEF-EXHAUST FAN MAXIMUM SPEED SETPOINT	AV	() HZ		X				D.E
REF-ST	RELIEF-EXHAUST FAN STATUS	BI			X	X	X		REF-ST <=> REF-C
REF-FLT	RELIEF-EXHAUST FAN VFD FAULT	BV			X	X	X		COMMON ALARM
SMOKE EXHAUST FAN									
SF-C	SMOKE EXHAUST FAN COMMENT (START/STOP)	BO							
SF-ST	SMOKE EXHAUST FAN STATUS	BI					X		RF-ST <=> RF-C
OUTSIDE AIR DAMPER									
OD-C	OUTSIDE AIR DAMPER COMMAND	BO		NC	X	X			
OD-ST	OUTSIDE AIR DAMPER STATUS	BI			X	X	X		OD-ST <=> OD-C
SMOKE PRESSURIZATION DAMPER (MODULATING)									
SPD-CO	SMOKE PRESSURIZATION DAMPER CONTROL OUTPUT	AO		NC					
SMOKE CONTROL DAMPER (2-POSITION)									
SCD-C-X	SMOKE ZONE CONTROL DAMPER COMMAND	BO		NC					DOA-ST <=> DOA-C
SCD-ST-X	SMOKE ZONE CONTROL DAMPER STATUS	BI							
SUPPLY AIR DIRTY FILTER INDICATION									
DF-SA	SUPPLY AIR FILTER PRESSURE DIFFERENTIAL	AI			X	X			
DF-SA-SP	SUPPLY AIR FILTER PRESSURE DIFFERENTIAL SETPOINT	AV	SCHED.				X		ON ACTIVATION D
OUTSIDE AIR DIRTY FILTER INDICATION									
DF-OA	OUTSIDE AIR FILTER PRESSURE DIFFERENTIAL	AI			X	X			
DF-OA-SP	OUTSIDE AIR FILTER PRESSURE DIFFERENTIAL SETPOINT	AV	SCHED.				X		ON ACTIVATION D
RELIEF/EXHAUST AIR DIRTY FILTER INDICATION									
DF-REA	RELIEF/EXHAUST AIR FILTER PRESSURE DIFFERENTIAL	AI			X	X			
DF-REA-SP	RELIEF/EXHAUST AIR FILTER PRESSURE DIFFERENTIAL SETPOINT	AV	SCHED.				X		ON ACTIVATION D
COOLING COIL - DX VARIABLE CONTROL									
DX-M-CO	DX MODULATING COMPRESSOR CONTROL OUTPUT	AO			X	X			
DX-M-ST	DX MODULATING COMPRESSOR STATUS	AI			X	X	X		DX-M-ST <=> DX-M-CO
DX-M-RUN	DX MODULATING COMPRESSOR RUNTIME	AV			X	X			
DEHUMIDIFICATION									
Z-H-SP	ZONE HUMIDITY SETPOINT	AV	50% RH		X				D
Z-H-DB	ZONE HUMIDITY DEADBAND	AV	5% RH		X				D
HOT GAS REHEAT COIL - DEHUMIDIFICATION									
HGRH-C	HOT GAS REHEAT COMMAND	BO			X	X			
HGRH-CO	HOT GAS REHEAT CONTROL OUTPUT	AO			X	X	X		
HEATING COIL - GAS FURNACE MODULATING									
HG-CO	GAS FURNACE HEAT MODULATION CONTROL OUTPUT	AO			X	X			
ENERGY RECOVERY - AIR SENSING									
OAT-D-SP	OUTSIDE AIR DEFROST SETPOINT	AV	15 F		X				D
FC-DLY	FROST CONTROL DELAY	AV	10 MIN		X				D
HR-DP	HEAT RECOVERY DIFFERENTIAL PRESSURE	AI			X	X			
HR-DP-SP	HEAT RECOVERY DIFFERENTIAL PRESSURE SETPOINT	AV	() IN W.G.		X				D.E
ENERGY RECOVERY - WHEEL CONSTANT SPEED									
HR-C	HEAT RECOVERY WHEEL COMMAND	BO			X	X			
HR-ST	HEAT RECOVERY WHEEL STATUS	BI			X	X	X		HR-ST <=> HR-C

